

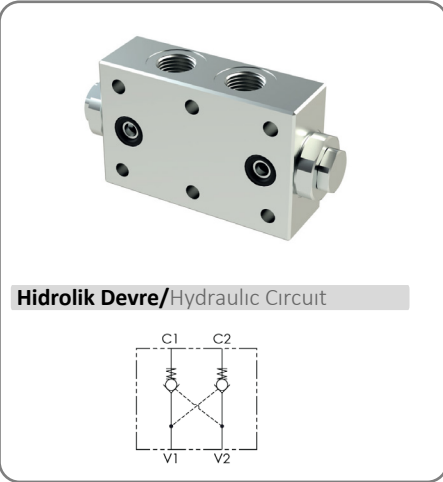

WINMAN VRDF Çek Valfler/ WINMAN VRDF Check Valves



Hidrolik Devre/Hydraulic Circuit

Teknik özellikleri/Technical Characteristics

01	VALVOLE DI BLOCCO FLANGIATA A DOPPIO EFFETTO (DOUBLE ACTING PILOT CHECK VALVES - FLANGED VERSION)		VRDF
02	DIMENSIONE (SIZE)	BSP 3/8	380
		BSP 1/2	120
03	MOLLA (SPRING)	1 bar (14.5 PSI)	1
		6 bar (87 PSI) Standard	6
04	O-RING SUL PISTONE DI PILOTAGGIO (O-RING ON PILOT PISTON)	Senza o-ring (without o-ring)	0
		con o-ring (with o-ring)	1
05	RAPPORTO DI PILOTAGGIO (PILOT RATIO)	1:3,2 solo per dimensione 120 (only for size 120)	32
		1:7	70

Performans/Performance

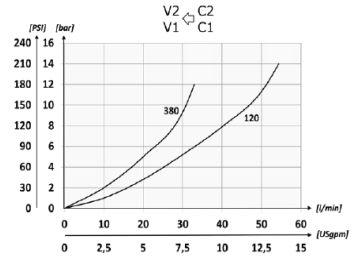
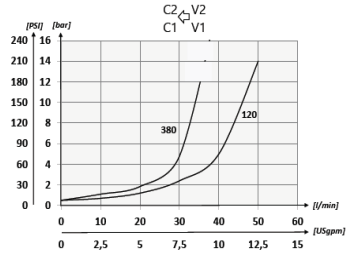

Teknik Çizim / Technical

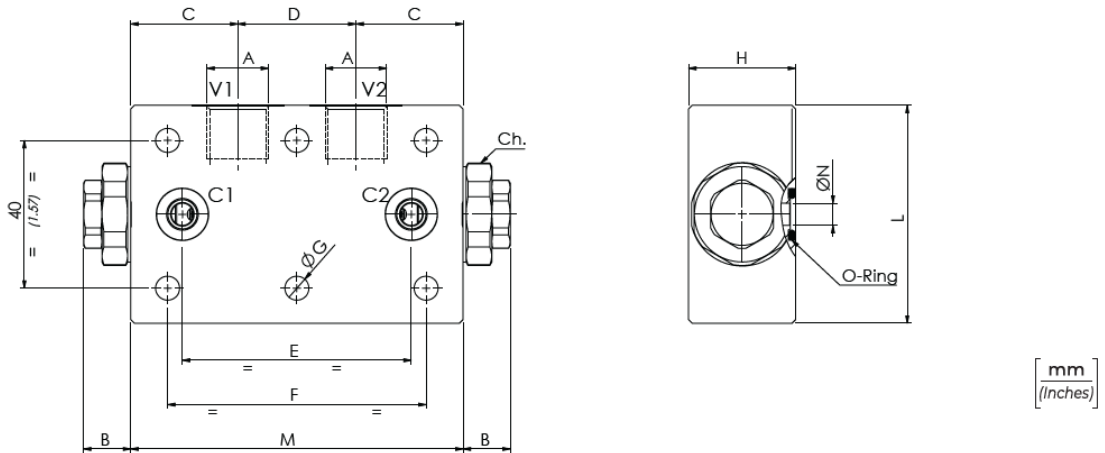

Olio idraulico - Mineral oil ISO 6743/4 (DIN 51524)
Viscosità olio - Oil viscosity 15-250 mm²/s (15 to 250 cSt)
Classe di contaminazione max ISO 4406:1999 Classe 19/17/14
 Max contamination index
Temperatura dell'olio - Oil temperature -20°C +80°C -4°F +176°F
Temperatura ambiente - Environment temperature -20°C +50°C -4°F +122°F

È indispensabile l'utilizzo di un filtro per proteggere la valvola (filtrazione consigliata 15 µm)
 It is necessary a filter use to protect the valve (advised filtration 15 µm)

Trafilamento massimo 0,25 cm³/min - 5 gocce/min
 Max leakage 0,015 in³/min - 5 drops/min

Sipariş Kodu/Ordering Code

TIPO TYPE	A	PORTATA MAX MAX FLOW l/min-USgpm	PRESSIONE MAX MAX PRESSURE bar-PSI	B	C	D	E	F	G	H	L	M	N	O-RING	PESO APPROX APPROX WEIGHT kg-lbt	RAPPORTO DI PILOTAGGIO PILOT RATIO
VRDF380	BSP 3/8	35 (9.2)	350 (5075)	12,8 (0.50)	29 (1.94)	32 (1.26)	62 (2.44)	70 (2.76)	6.5 (0.26)	34 (1.34)	59 (2.32)	90 (3.54)	Ø 6 (0,24)	9,19x2,62	1,11 (2.44)	1:7
VRDF120	BSP 1/2	50 (13.2)		14,8 (0.58)	38 (1.50)	34 (1.34)	65 (2.56)	80 (3.15)	8.5 (0.33)		69 (2.72)	110 (4.33)	Ø 7 (0,28)	15,08x2,62	1,85 (4)	1:3,2
																1:7