

TEK ETKİLİ KARŞI DENGE VALFLERİ SINGLE ACTING OVERCENTER VALVES

VBCL

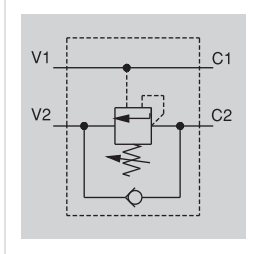

Tek etkili karşı denge valf tipi VBCL yükün inişinin kontrolü ile tek etkili silindirin durmasını sağlar.

The single acting overcenter valves type VBCL allow both the descent control of a load and the stop of a single acting cylinder

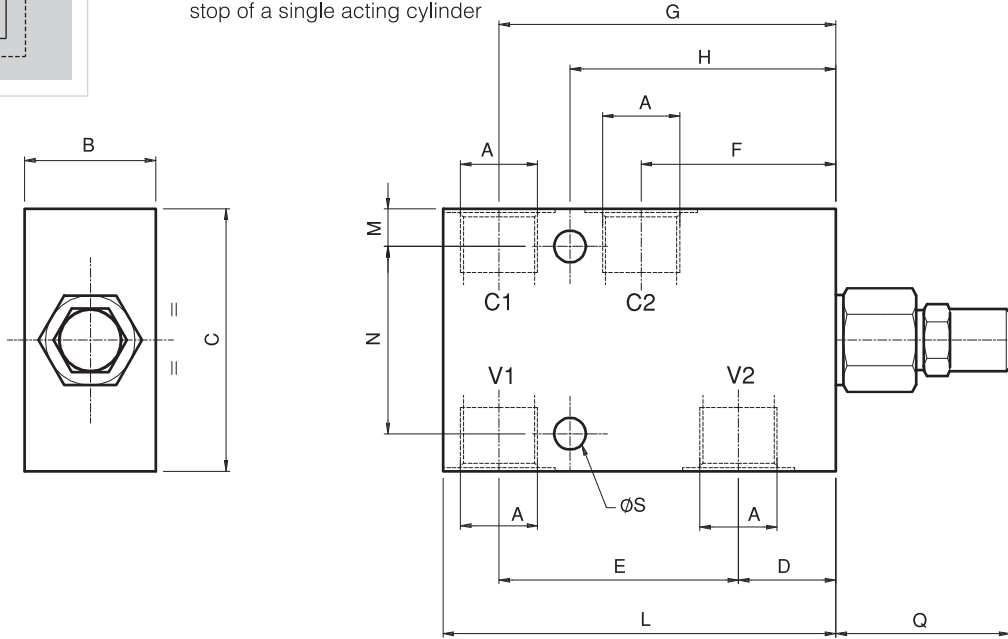

TEKNİK ÖZELLİKLER / FEATURES

Kod Code	A	Max. Debi Max flow l/min	Max. Basınç Max pressure bar	B	C	D	E	F	G	H	L	M	N	Q	S	Pilot Oranı Pilot ratio	Ağırlık Weight Kg
VBCL140	BSPP 1/4	30	210	30	60	26	64	52	90	71	105	10	40	46,5	6,5	1:4,25	0,62
VBCL380	BSPP 3/8	40		30	60	26	64	52	90	71	105	10	40	46,5	6,5		0,58
VBCL120	BSPP 1/2	60		35	70	26	64	52	90	71	105	10	50	46,5	8,5		0,60

SİPARİŞ KODU / ORDERING CODE

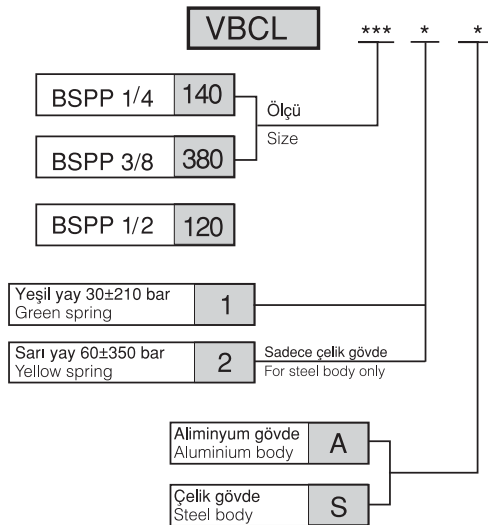

BASINÇ ÇİZGİLERİ/ PRESSURE DROPS

