

Ordering Code

WPAC - 091 - - - - -
1 2 3 4 5 6 7
 Model Size Stroke Pitch Mounting Kit Model Mounting Kit Assembly Assembly Accessories

1-Model

WPAC: Series Linear Actuators

2-Size

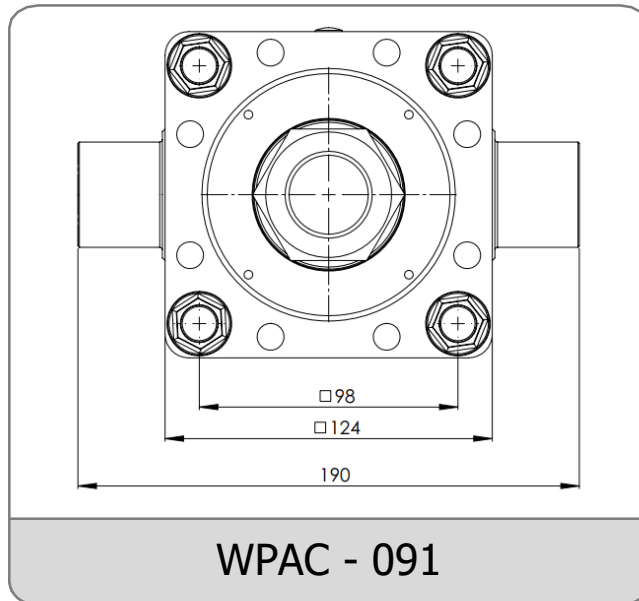

3-Stroke

0000 : Maximum 1500 mm

Movement Stroke

In addition to the desired movement stroke, it is recommended to leave a space on both sides until 2 x Pitch.

$$S_m = S_e + 2 \times S_s$$

$$S_s = 2 \times p$$

S_m : Movement Stroke

S_e : Safety Stroke

P : Pitch

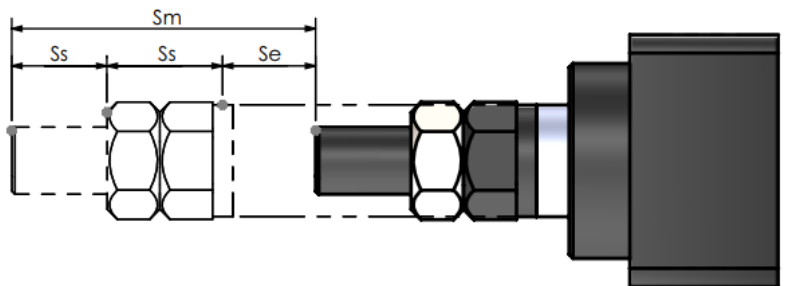

Ordering Code

WPAC - 091 -
1
2
3
4
5
6
7
 Model Size Stroke Pitch Mounting Kit Model Mounting Kit Assembly Assembly Accessories

4-Pitch

Drive Unit	Screw
Actuator Model	10
WPAC - 091	+

5-Mounting Kit Model

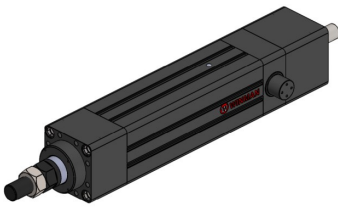
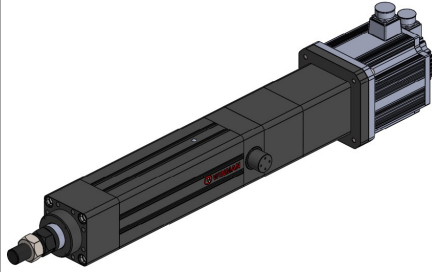
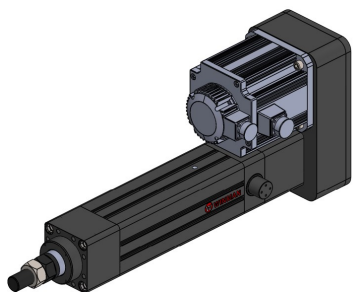
		
00: Without Mounting (Standart)	WDAK : Axial Kit	WDPK : Parallel Kit

Note 1 : Please contact for different motor types and mounting sizes.

Note 2 : Please contact for to use reducer.

6-Assembly Accessories**Front Mounting**

... - WGM1

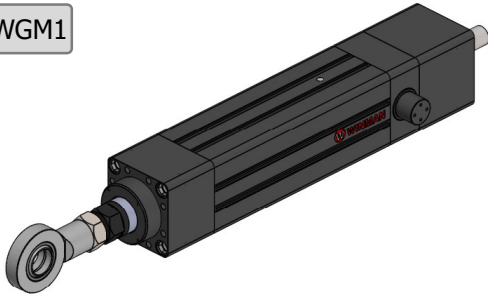

... - WGM2

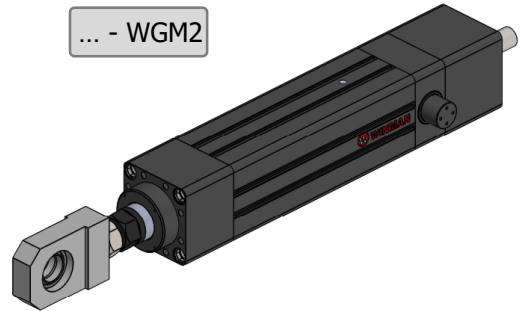
**Mounting for Axial Kit**

... - FTC

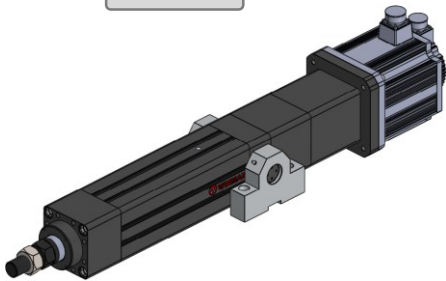

... - WFB

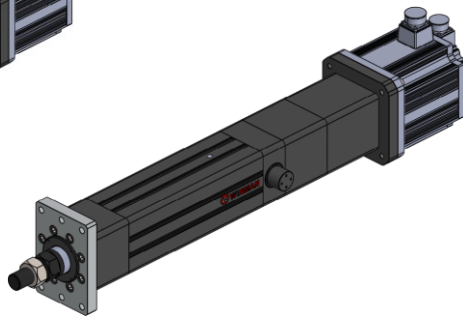

... - WAB

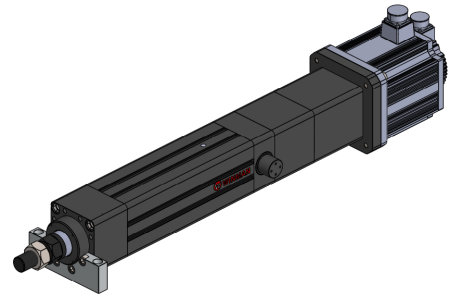
**Mounting for Parallel Kit**

... - FTC

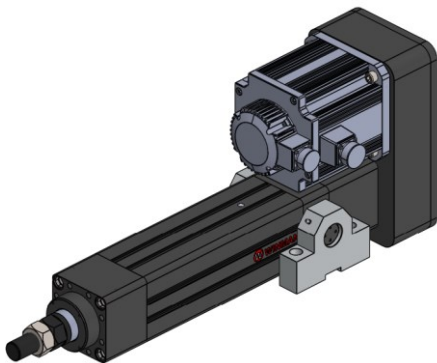

... - WFB

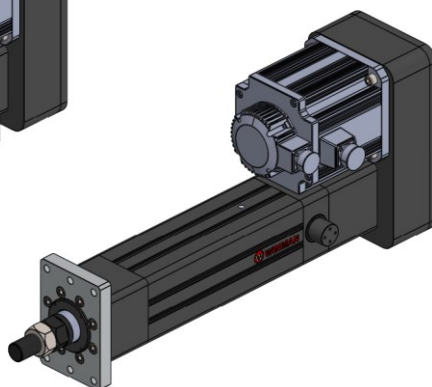

... - WAB

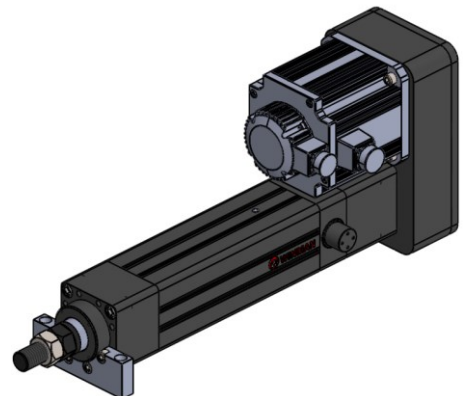

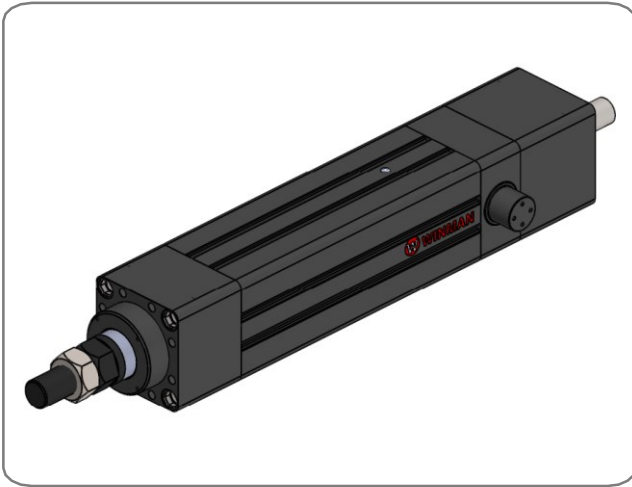
WINMAN WPAC-091 Series Linear Actuators

Specification		
Size		091
Maximum Axial Force	N	91000
Maximum Speed	m/s	0,5
Maximum Stroke	mm	1500
Acceleration	m/s ²	30

Note : Calculated value are theoretical values. We recommend you to calculate safety factor as five (5).

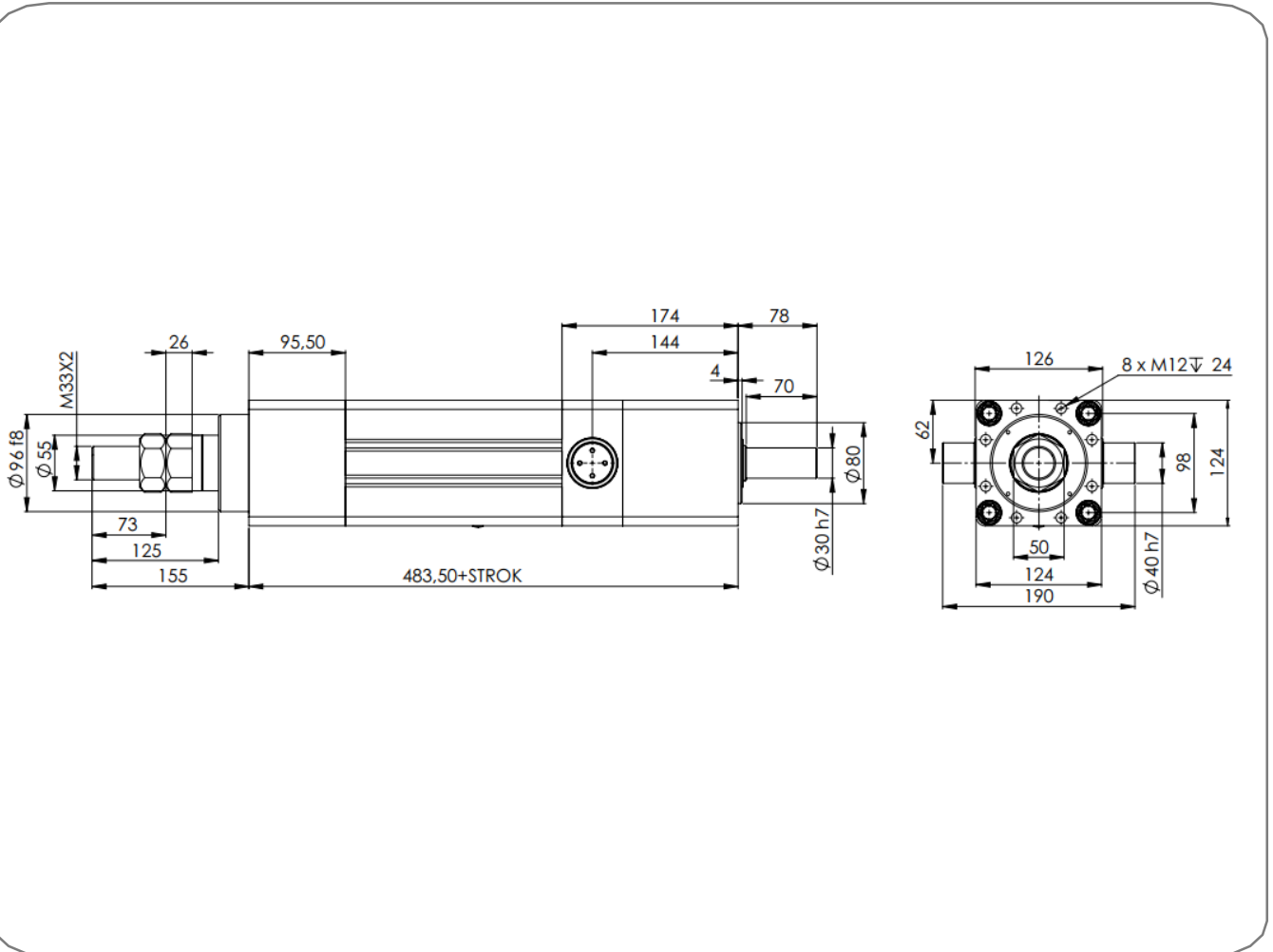
Technical Drawing

Technical Data

Mean Force/Service Life

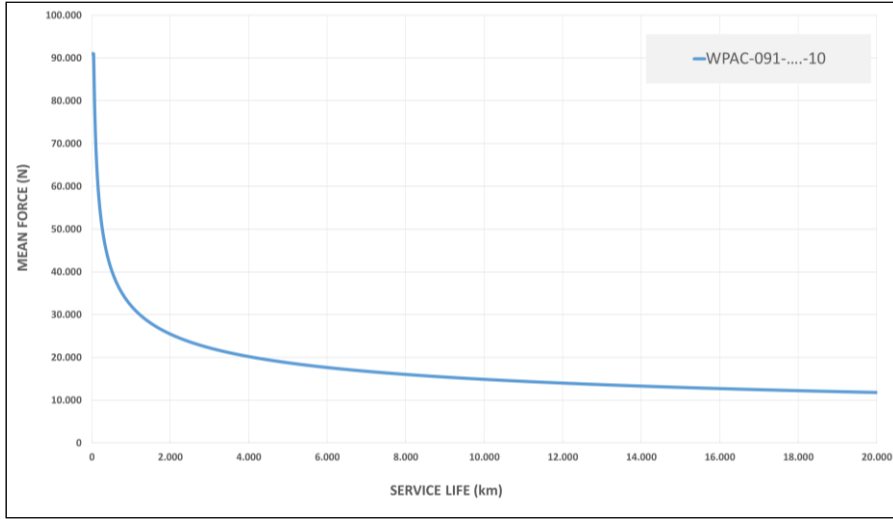

Permissible Speed/Stroke

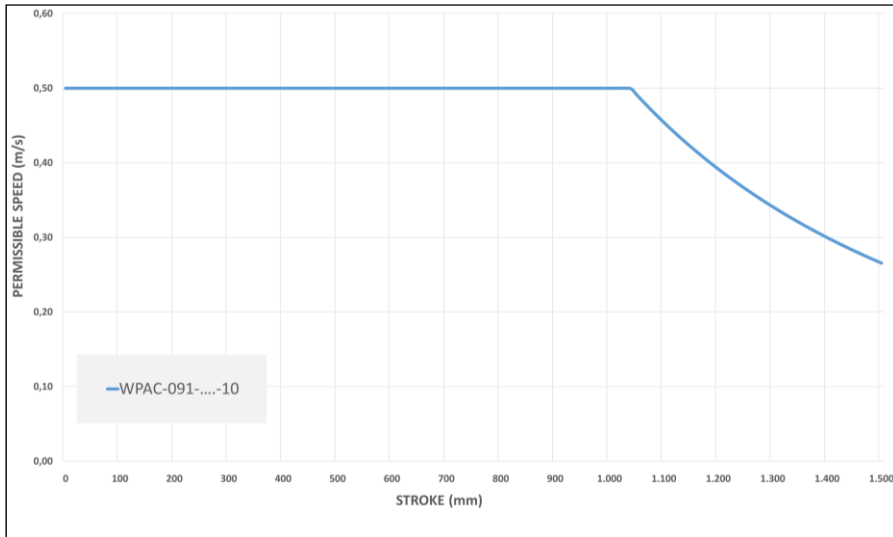

Maximum Force/Stroke

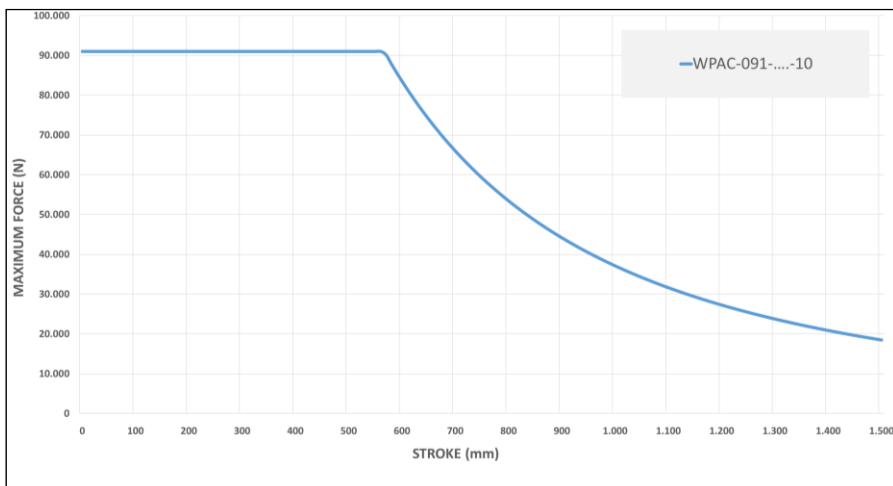

WDAK Axial Mounting Kit

WDAK Technical Drawing

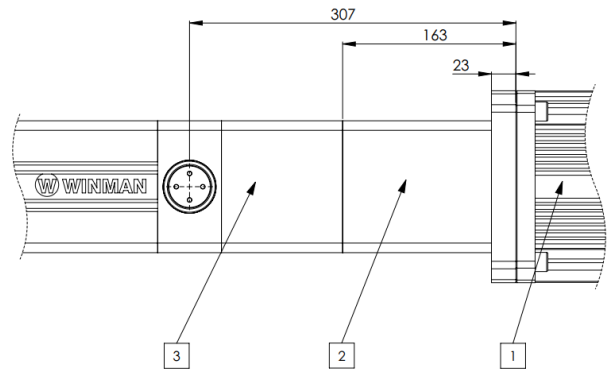
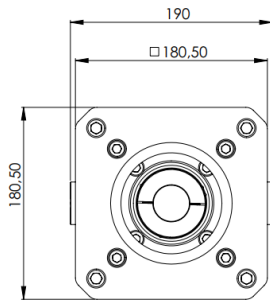
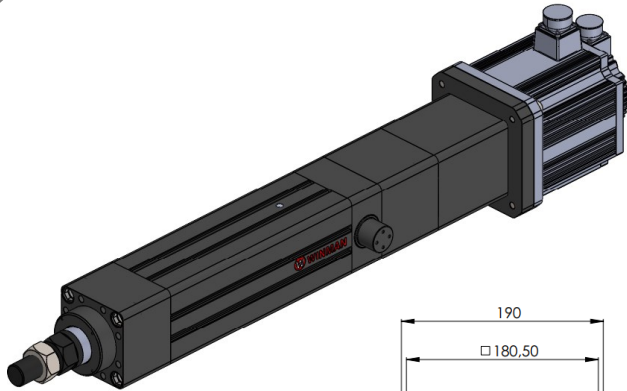

- 1 – Motor
- 2 – Axial Kit
- 3 – Linear Actuator

WDAK Axial Foot Mounting Kit

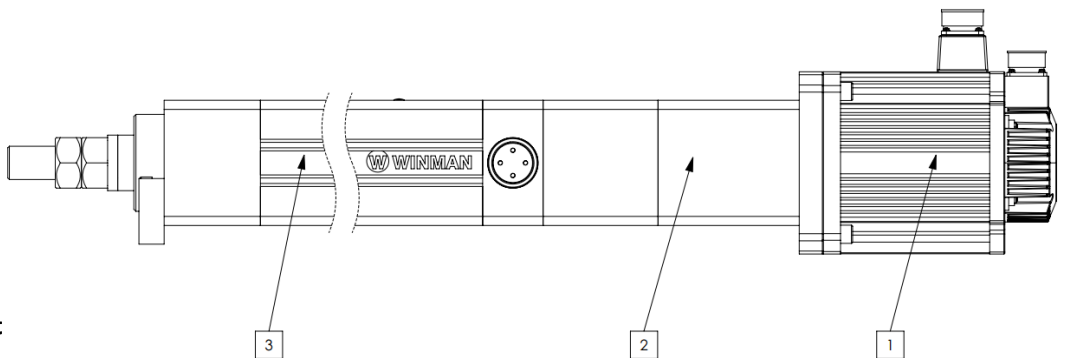
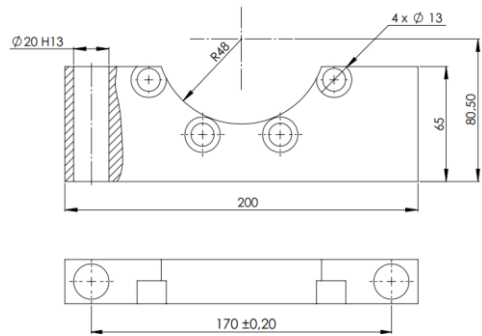
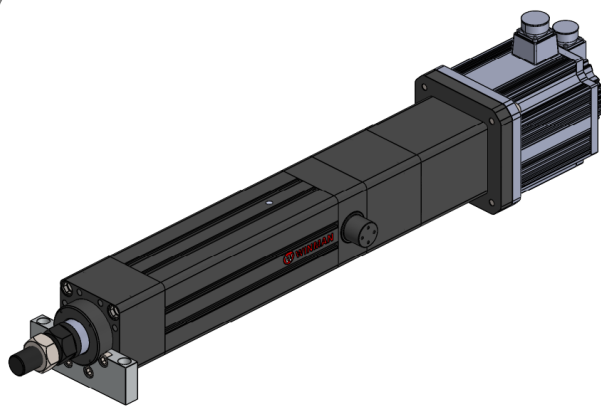

- 1 – Motor
- 2 – Axial Kit
- 3 – Linear Actuat

WDPK Parallel Mounting Kit

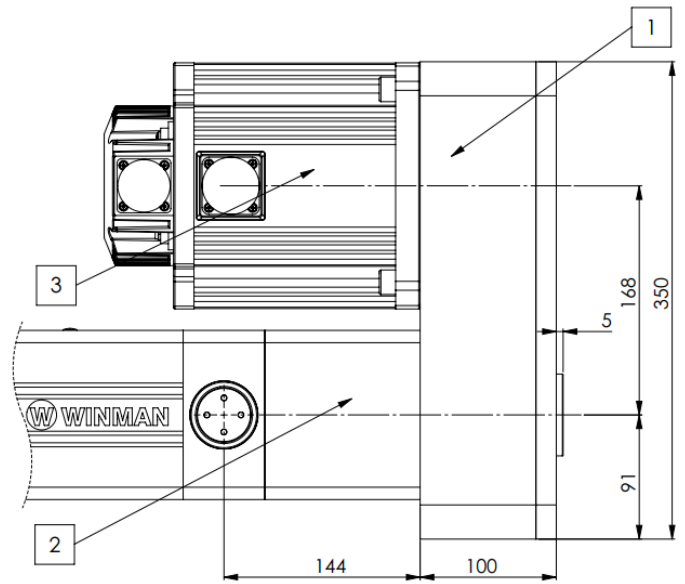
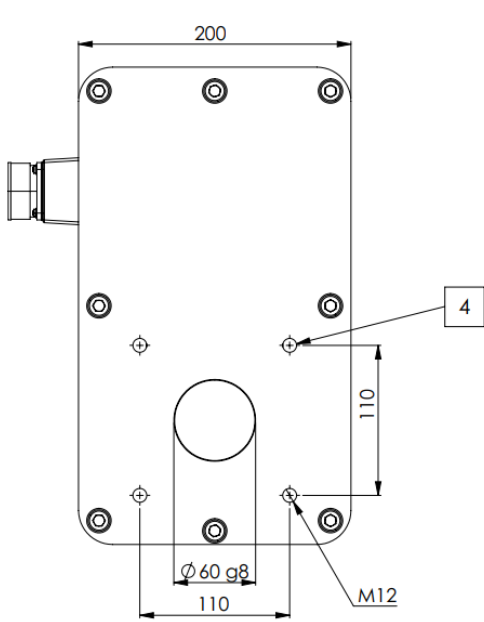
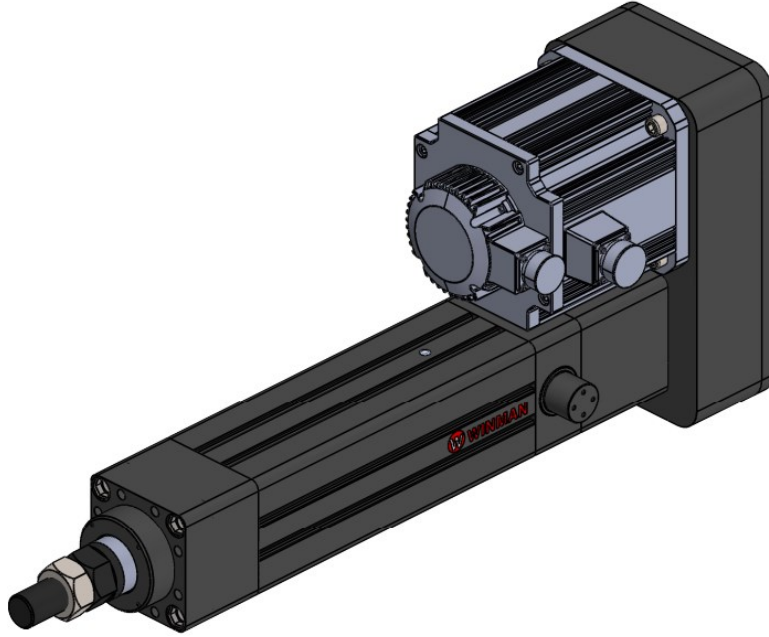

- 1 - Parallel Kit
- 2 - Linear Actuator
- 3 - Motor
- 4 - Mounting Thread

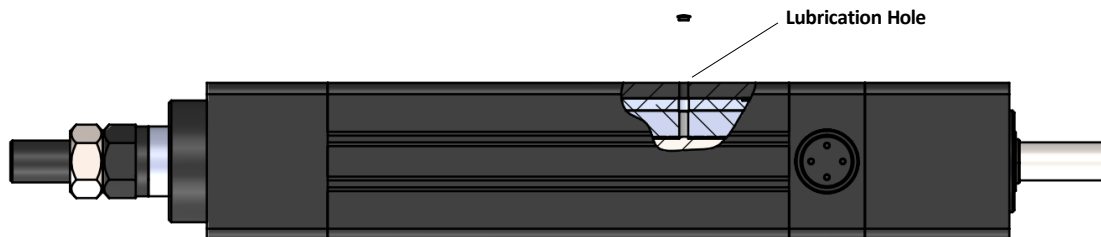
Maintenance

Basic lubrication is done in-factory before shipment.

Bearings of the ball screw have been lubricated for life and will not require in-service lubrication under normal operating conditions.

The profile of the linear actuator has port on the top side for access to the lube on the ball nut.

Re-lubrication should be carried out if the defined travel distance is completed or 400 operating hours are reached first. At the end of 2 years, it must be re-lubricated even if the travel distance and working hours are not reached.

For lubrication; set linear actuator to zero stroke position. Remove the grubs in the lubrication port lubricate the amount indicated in the table and replace the glue after lubrication, move the linear actuator at least three times along the stroke distance. the travel speed must not exceed 10 mm / s.

Linear actuators must be lubricated with suitable grease.

Lithium soap grease should be used.

Caution: Do not use grease containing graphite or MoS!

Lubrication quantity is provided in table by normal operating conditions.

Normal Working Conditions

Note : The lubrication quantity specified in the table is valid for normal operating conditions. The lubrication quantity may vary in different operating conditions. Get information for the lubrication quantity in different working conditions.

Ambient Temperature	°C	10 ~ 40 / -20 ~ 50
Speed	m/s	≤ 0,4
Screw Rotation Speed	rev/min	3000
Load	N	≤ 0,2 C
Stroke	mm	>110

Lubrication

Actuator Model		WPAC-091
Lubrication Period	km	600
	h	400
Lubrication Dose	cm³	3,7

Our company has the right to modify change images, dimensions and other datas which take place in this catalogue.