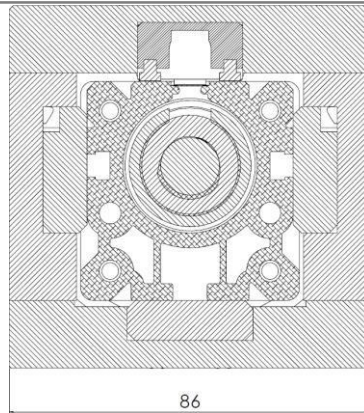

Ordering Code
WMMS - LS - 032 - _ _ _ _ - 04

1	2	3	4	5
Model	Drive Unit	Size	Stroke	Pitch

1 - Model
WMMS: Series Manual Linear Module

2 - Drive Unit
LS: Lead Screw

3 - Size

WMMS – LS - 032
4 - Stroke
0000: Maximum 500 mm

Movement Stroke

In addition to the desired movement stroke, it is recommended to leave a space on both sides until 2xPitch.

$$S_m = S_e + 2 \cdot S_s$$

$$S_s = 2 \cdot P$$

S_m : Movement Stroke
 S_e : Safety Stroke
 P : Ball Screw Pitch

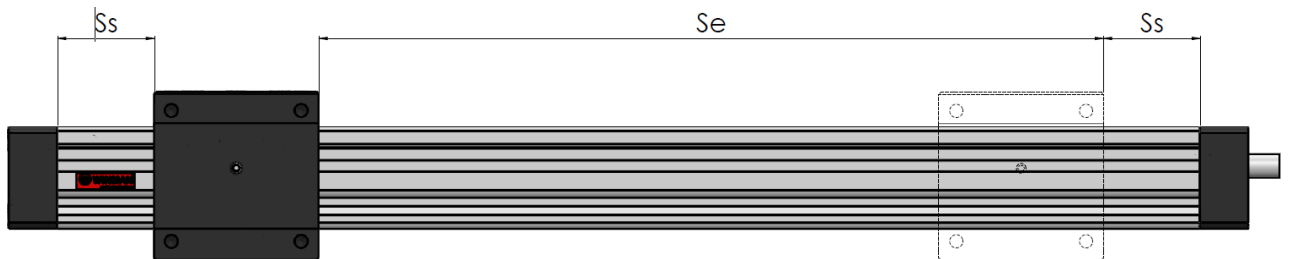

5 - Lead
04 : 4 mm/rev

WINMAN WMMS-032 Series Manuel Linear Modules

Specification

Maximum Stroke [mm]	500		
Position Accuracy [$\mu\text{m}/\text{mm}$]	$\pm 150/300$		
Maximum Speed [mm/sec.]	20		
Screw Lead [mm]	4		
Maximum Permissible Torsional Moment Around The Axis [Nm]	M_x max	M_y max	M_z max
	52	70	47
Maximum Load in Directions [Nm]	F_y max		F_z max
	2090		2185

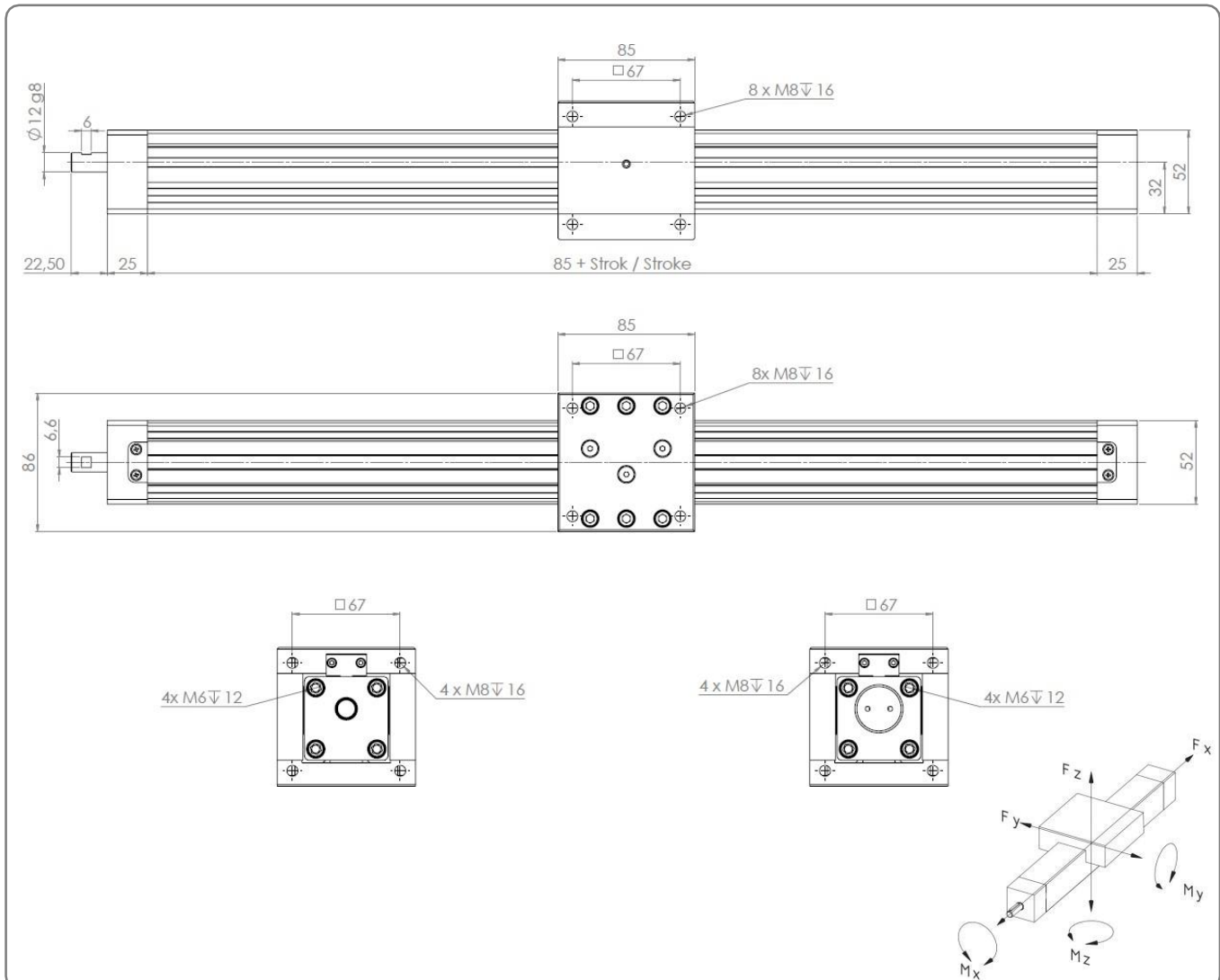
Note : Calculated value are theoretical values. We recommend you to calculate safety factor as five (5).

Technical Drawing



Assembly

WMMS Manuel Module

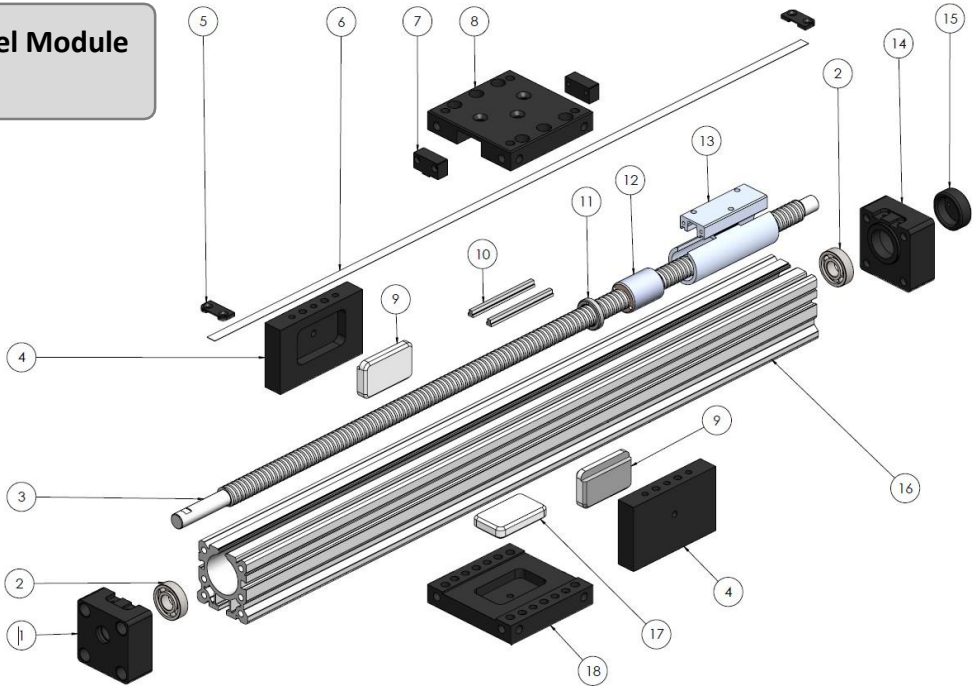

Piece	Qty	Part Name	Assembly
1	1	Front Block	Module
2	2	Bearing	
3	2	Lead Screw	
4	2	Side Mounting Plate	
5	1	Strip Mounting Piece	
6	2	Steel Strip	
7	1	Strip Pressure Part	
8	2	Upper Mounting Plate	
9	2	Side Support Part	
10	1	Carriage Support Part	
11	1	Trapezoidal Nut Thrust Nut	
12	1	Trapezoidal Nut	
13	1	Carriage	
14	1	Back Block	
15	1	Back Bearing Pressure Nut	
16	1	Profile	
17	1	Lower Support Part	
18	1	Lower Mounting Plate	