

Ordering Code

WMCD - BS - 110 - _ _ - _ _ - _ _ - _ _ - _ _

1 2 3 4 5 6 7 8
 Model Drive Unit Size Stroke Pitch Mounting Kit Model Mounting Kit Assembly Mounting Kit Side

1 - Model

WMCD : Compact Linear Module

2 - Drive Unit

BS : Ball Screw

3 - Size

<p>Standard</p> <p style="text-align: center;">110</p> <p style="text-align: center;">WMCD - BS - 110</p>	<p>Option</p> <p>Magnetic Sensing Order the Magnetic Sensor and the WMCD 110 Sensor Bracket separately.</p> <p style="text-align: center;">_ _ - MS</p>
------------------------------------------------------------------------------------------------------------------	-------------------------------------------------------------------------------------------------------------------------------------------------------------

4 - Stroke

0000 : Maximum 1400 mm

Movement Stroke

In addition to the desired movement stroke, it is recommended to leave a space on both sides until 2xPitch.

$$S_m = S_e + 2 \cdot S_s$$

$$S_s = 2 \cdot p$$

S_m : Movement Stroke
 S_e : Safety Stroke
 p : Ball Screw Pitch

5 - Pitch

- 05 : 5 mm/rev
- 10 : 10 mm/rev
- 16 : 16 mm/rev

Ordering Code

WMCD - BS - 110 - - - - -

- | | | | | | | | |
|-------|------------|------|--------|-------|--------------------|-----------------------|-------------------|
| 1 | 2 | 3 | 4 | 5 | 6 | 7 | 8 |
| Model | Drive Unit | Size | Stroke | Pitch | Mounting Kit Model | Mounting Kit Assembly | Mounting Kit Side |

6 - Mounting Kit Model



		
00 : Without Mounting (Standard)	WDAK : Axial Kit	WDPK : Parallel Kit

Note 1 : Please contact for different motor types and mounting sizes.
 Note 2 : Please contact for to use reducer.

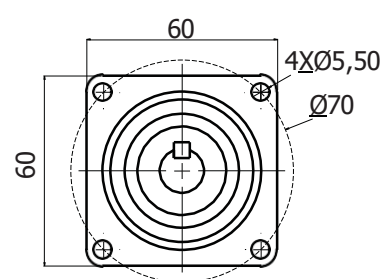
7 - Mounting Kit Assembly

	
00 : Without Motor (Standart)	070 : Ø70 motor mounting

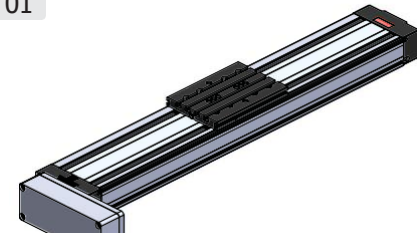
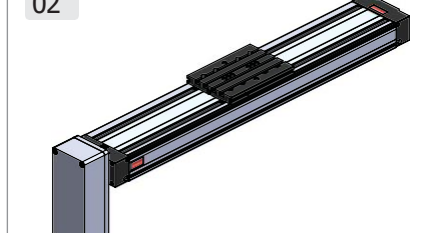
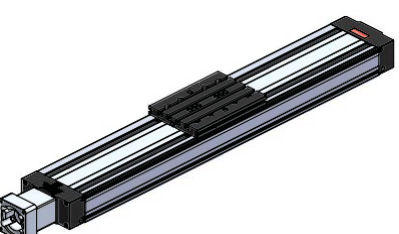
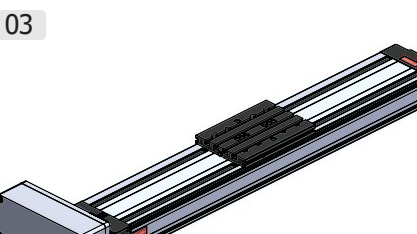
8 - Mounting Kit Side

00 Standard 	01 	02 
	03 	04 

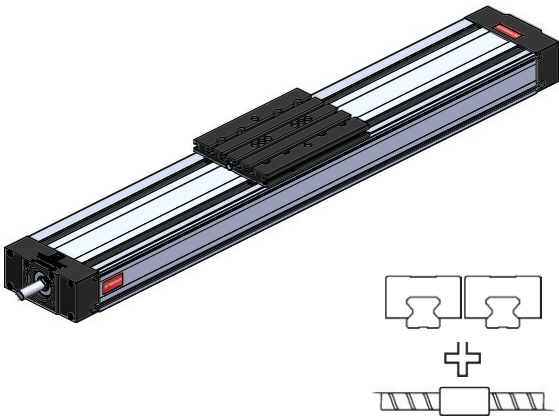
WINMAN WMCD-110 Series Compact Linear Module

Specification

Maximum Stroke [mm]		1400			
Position Accuracy [$\mu\text{m}/\text{mm}$]		53/300			
Repeating Accuracy [mm]		< 0,05			
Acceleration [m/s^2]		10			
Screw Lead [mm]	Dynamic Load Capacity [N]		Dynamic Torsional Moment Load Capacity [Nm]		
	C	C_{bs}	M_t	M_L	
	5	9260	1890	3000	
	10	10420			
16	7350				
Max. Permissible Torsional Moment Around The Axis [Nm]			Max. Dynamic Load in Directions [N]		
$M_x \text{ max}$	$M_y \text{ max}$	$M_z \text{ max}$	$F_y \text{ max}$	$F_{z1} \text{ max}$	$F_{z2} \text{ max}$
700	1110	540	6660	13690	13690

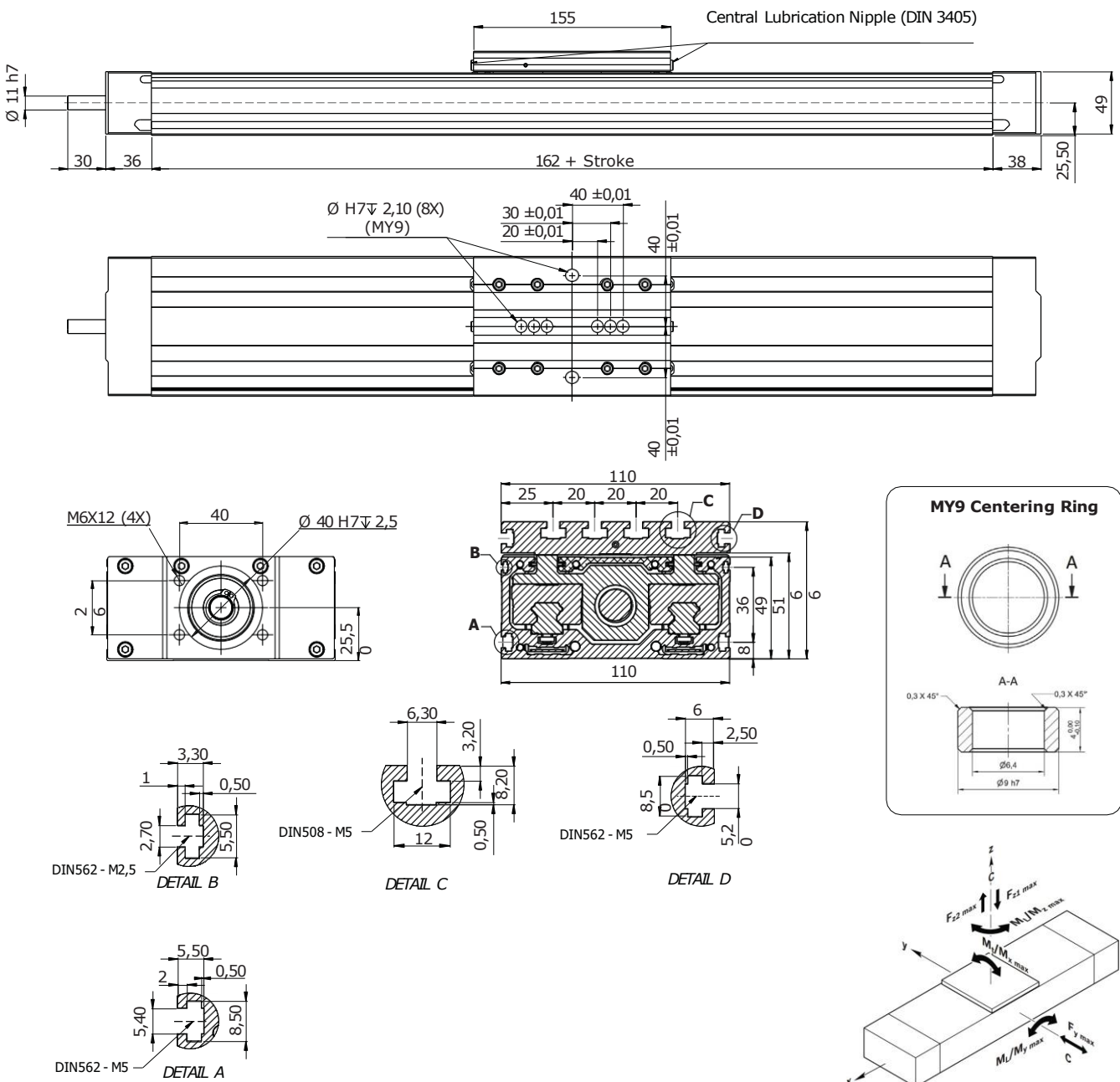
Note : Calculated value are theoretical values. We recommend you to calculate safety factor as five(5).

Technical Drawing

WDAK Axial Mounting Kit

Technical Drawing

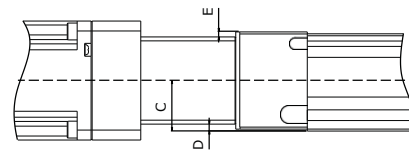
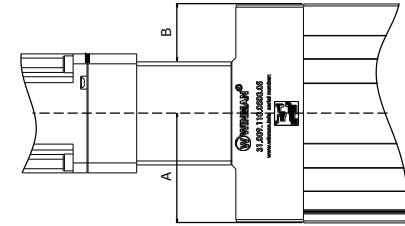
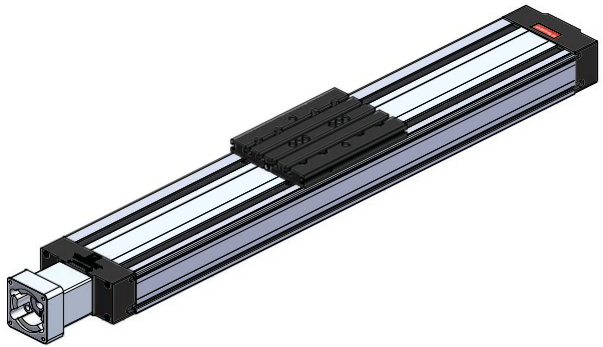

Mounting Kit Type	A	B	C	D	E
WDAK-070	55	29	25,50	3,50	2,50

Bell housing

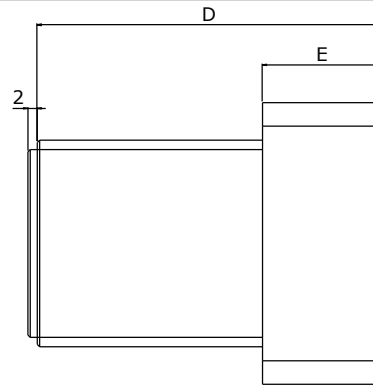
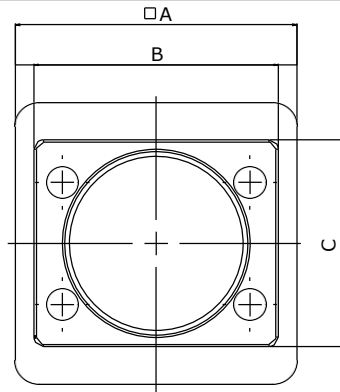

Mounting Kit Type	A	B	C	D	E
WDAK-070	60	52	44	73	25

Coupling

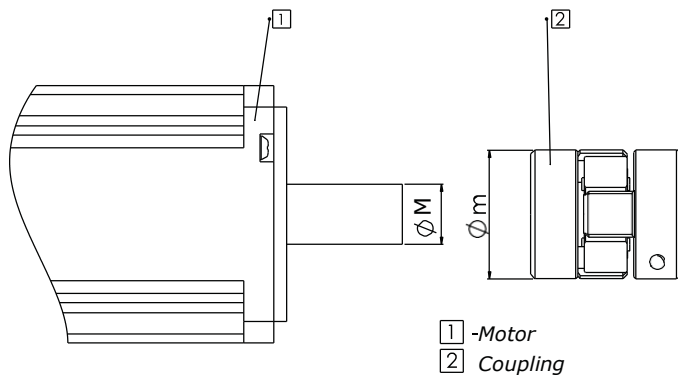

- 1 -Motor
- 2 Coupling

Mounting Kit Type	M	m	Coupling Model
WDAK-070	14	30	WWJL - 30CRD

WDPK - Parallel Mounting Kit

Technical Drawing

WDPK - __ - 01

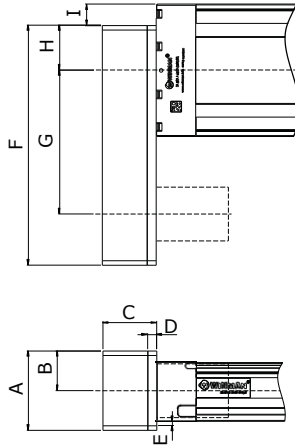
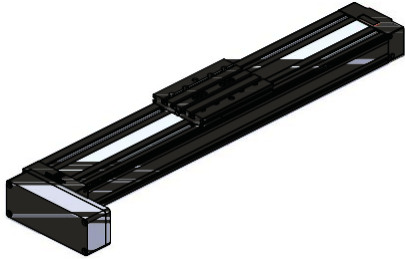

Kit Assembly	WDPK - 070 - 01
A	64,50
B	32,25
C	50
D	10
E	6,75
F	179
G	100
H	39
I	15,50

WDPK - __ - 02

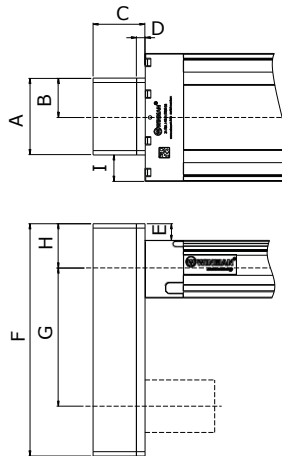
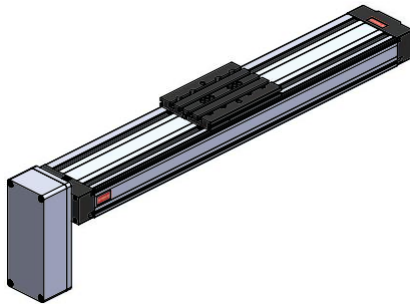

Kit Assembly	WDPK - 070 - 02
A	64,50
B	32,25
C	50
D	10
E	14,50
F	179
G	100
H	39
I	22,25

WDPK - __ - 03

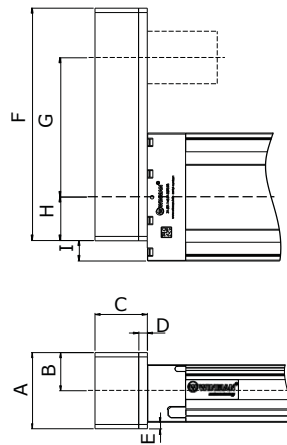
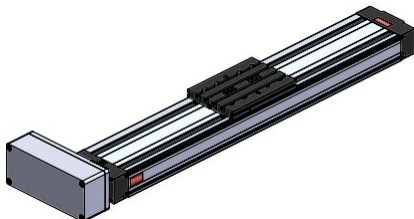

Kit Assembly	WDPK - 070 - 03
A	64,50
B	32,25
C	50
D	10
E	7,50
F	179
G	100
H	39
I	15,50

WDPK - __ - 04

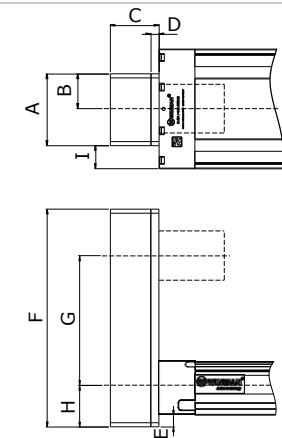

Kit Assembly	WDPK - 070 - 04
A	64,50
B	32,25
C	50
D	10
E	14,50
F	179
G	100
H	39
I	22,50

Assembly

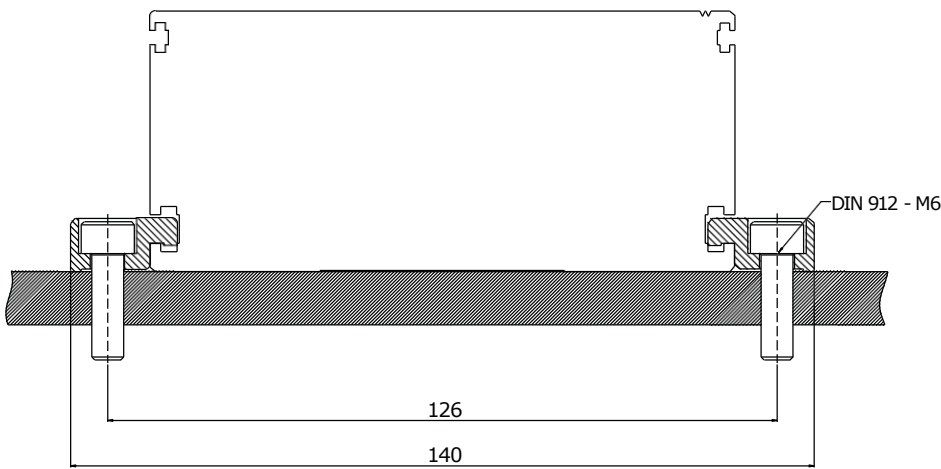
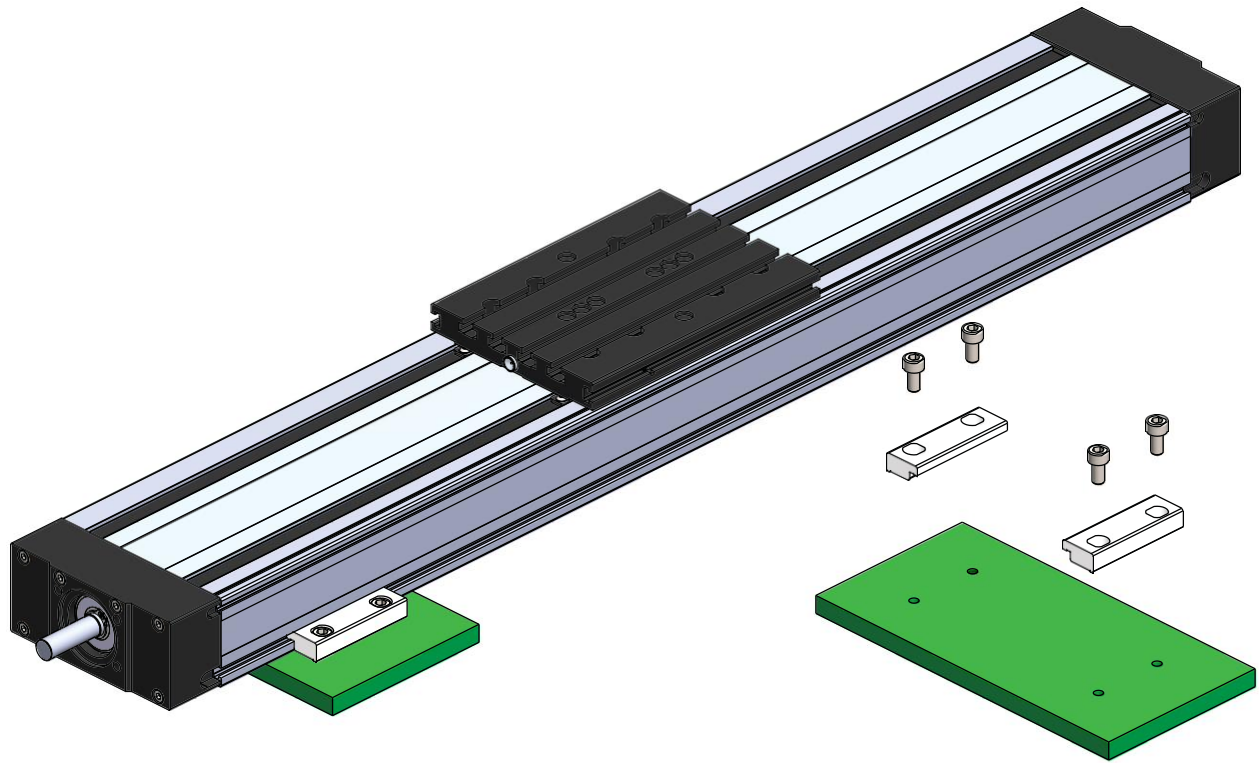

WMCD 110
Clamping Fixtures

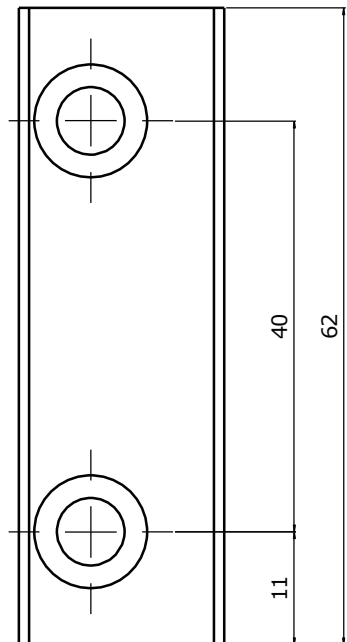

Assembly

WMCD Linear Module

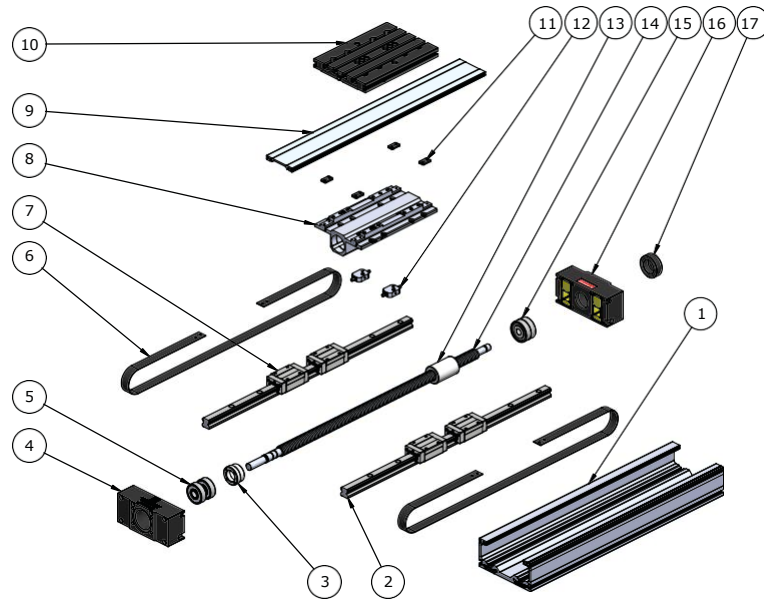

WDPK Parallel Kit

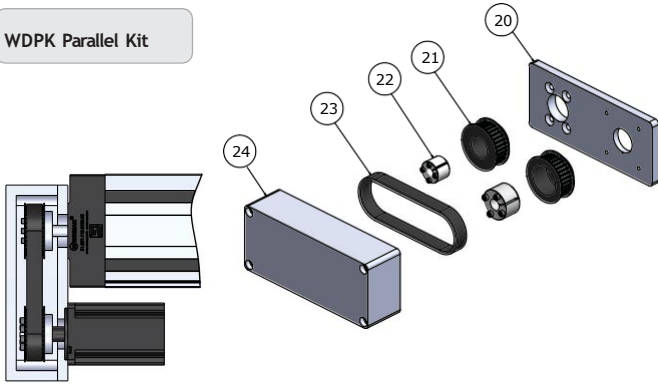

WDAK Axial Kit

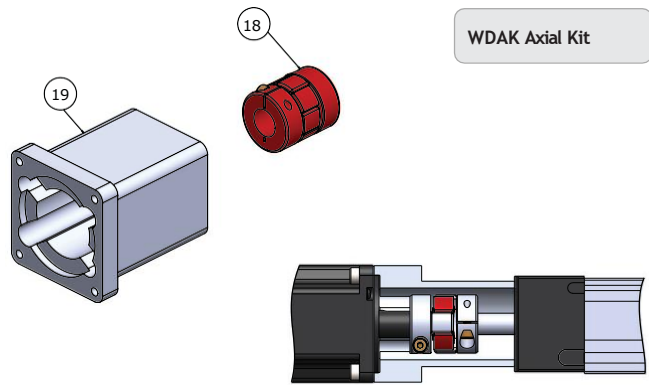

Piece	Qty	Part Name	Assembly
1	1	Profile	Module
2	2	Linear Guide	
3	1	Front Bearing Pressure Nut	
4	1	Front Block	
5	2	Front Bearing	
6	2	Protection Strip Corrosion Resistans	
7	4	Linear Carriage	
8	1	Mounting Plate	
9	1	Carriage	
10	1	Profile Cover	
11	4	Strip Mounting Piece	
12	2	Lubrication Port	
13	1	Ball Nut	
14	1	Ball screw	
15	1	Back Bearing	
16	1	Back Block	
17	1	Back Bearing Pressure Nut	
18	1	Coupling	Axial Kit
19	1	Bell housing	Parallel Kit
20	1	Parallel Kit Cover	
21	2	Timing Belt Pulleys	
22	2	Taper Bushing	
23	1	Toothed Belt	
24	1	Parallel Kit Box	

Maintenance

Basic lubrication is done in-factory before shipment.

Bearings of the ball screw have been lubricated for life and will not require in-service lubrication under normal operating conditions.

The lubrication of ball nuts and carriages is made from a single port

Compact modules must be lubricated with suitable grease.

Lithium soap grease should be used.

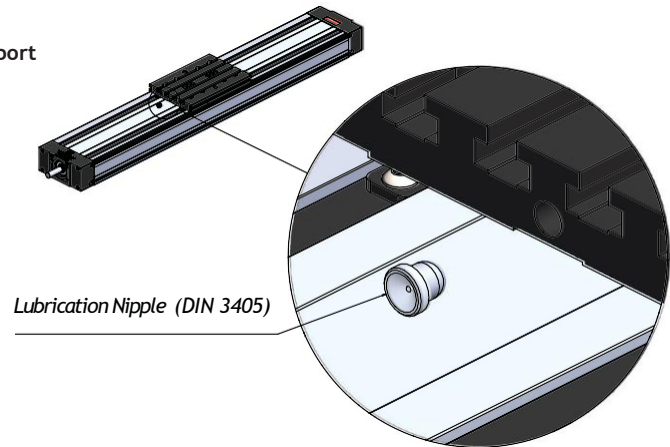

Caution: Do not use grease containing graphite or MoS!

Lubrication is performed every 400 hours or 400 km total working distance by normal operating conditions.

Lubrication quantities are provided in table by normal operating conditions.

After lubrication, move the linear module at least three times. Do not exceed the movement value, the movement speed 10 mm / s.

Belt is assembled with a fixed axis distance between the pulleys in Parallel Kits. In consequence there is no need to adjust the tension of belt.

After maintenance, get information about the protection strip tension on the module.

Normal Working Conditions

Note : The lubrication quantity specified in the table is valid for normal operating conditions. The lubrication quantity may vary in different operating conditions. Get information for the lubrication quantity in different working conditions.

Ambient Temperature	°C	10 ~ 40
Speed	m/s	≤ 1,0
Screw Rotation Speed	rev/min	2500
Load	kN	≤ 0,2 C
Stroke	mm	> 60
Lubrication Period	Km	400
	Hour	400
Lubricate Dose	cm ³	5,2