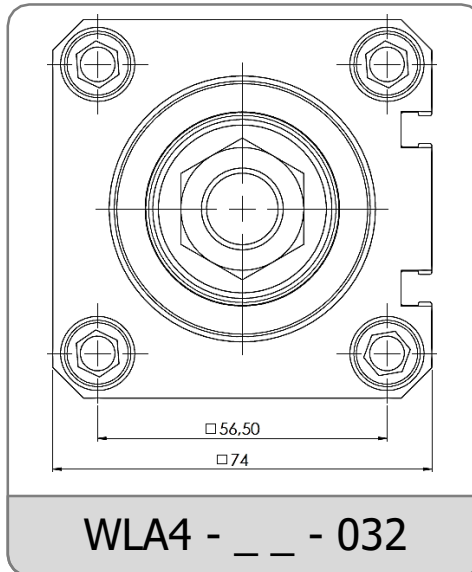

Ordering Code

WLA4 - **BS** - **032** - _ _ _ - _ _ - _ _ - _ _ - _ _ - _ _
1 2 3 4 5 6 7 8
 Model Drive Unit Size Stroke Pitch Mounting Kit Model Mounting Kit Assembly Assembly Accessories

1-Model
WLA4: Series Linear Actuators

2-Drive Unite
BS: Ball Screw

3-Size

4-Stroke
0000 : Maximum 600 mm

Movement Stroke

In addition to the desired movement stroke, it is recommended to leave a space on both sides until 2 x Pitch.

$$S_m = S_e + 2 \times S_s$$

$$S_s = 2 \times p$$

S_m : Movement Stroke

S_e : Safety Stroke

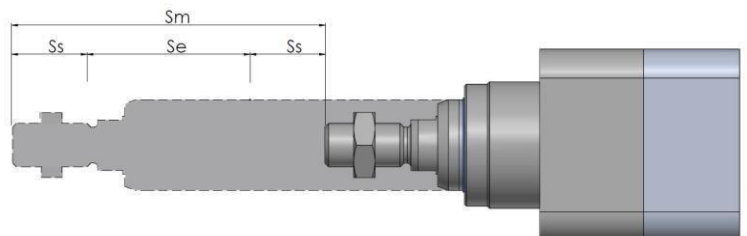
P : Ball Screw Pitch

Ordering Code
WLA4 - BS - 032 -

1	2	3	4	5	6	7	8
Model	Drive Unit	Size	Stroke	Pitch	Mounting Kit Model	Mounting Kit Assembly	Assembly Accessories

5-Pitch

Drive Unit	Ball Screw	
Actuator Model	5	10
WACE - _ - 063	+	+

6-Mounting Kit Model

00: Without Mounting (Standart)	WDAK : Axial Kit	WDPK : Parallel Kit

Note 1 : Please contact for different motor types and mounting sizes.

Note 2 : Please contact for to use gearbox.

7-Mounting Kit Assembly

00: Without Motor (Standart)	070: Ø70 Motor Mounting	090: Ø90 Motor Mounting

8-Assembly Accessories

Front Mounting

... - WKA



... - WGM



... - WCB



... - WHCR B



... - WUCR B

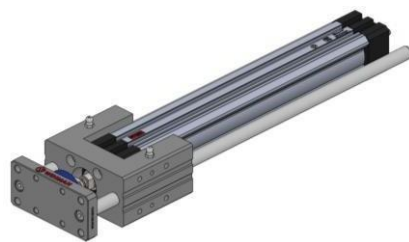

Mounting for Axial Kit

... - FTC



... - WFB



... - WAB



Mounting for Parallel Kit

... - FTC



... - WFB



... - WAB



... - EYB

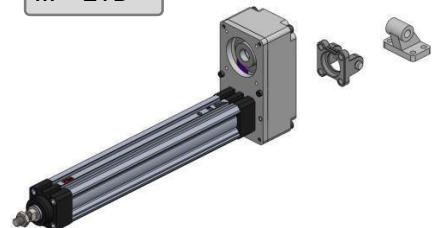

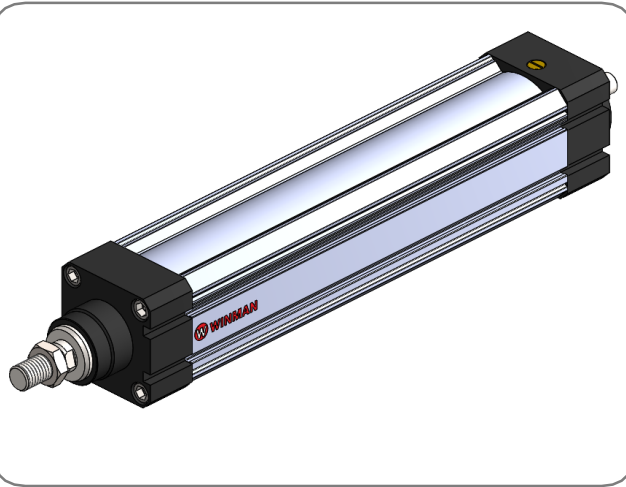
WINMAN WLA4-032 Series Linear Actuators

Specification			
Size		032	
Ball Screw Lead		005	010
Maximum Axial Force	N	1000	
Maximum Speed	m/s	0.50	1.00
Maximum Stroke	mm	600	
Position Accuracy	$\mu\text{m}/\text{mm}$	53/300	
Repeating Accuracy	mm	<0.05	
Acceleration	m/s^2	10	

Note : Calculated value are theoretical values. We recommend you to calculate safety factor as five (5).

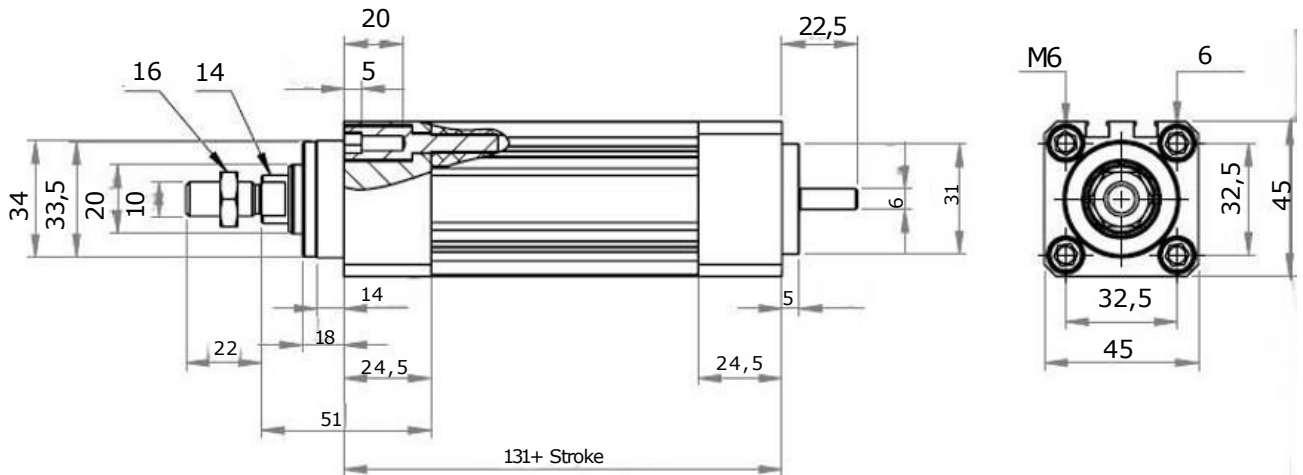
Technical Drawing

Technical Data

Mean Force/Service Life

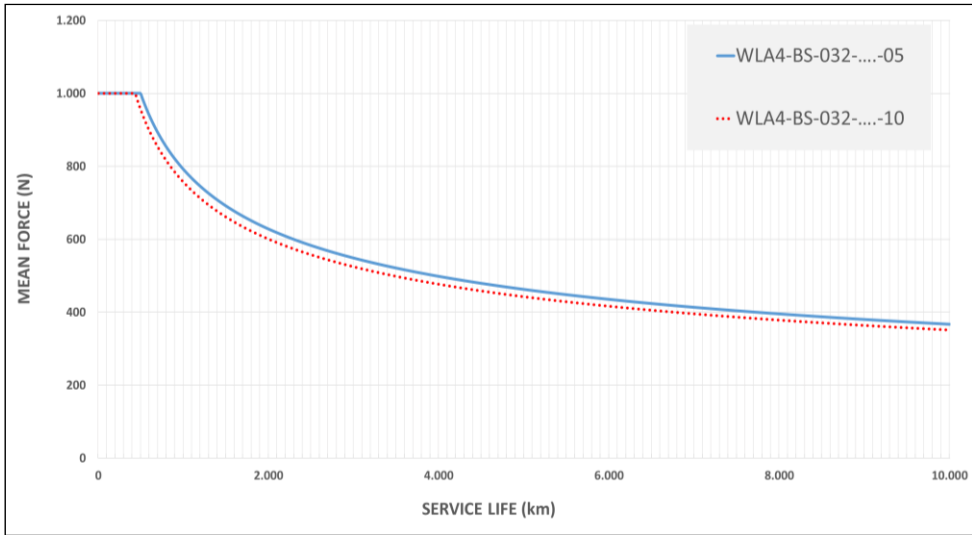

Permissible Speed/Stroke

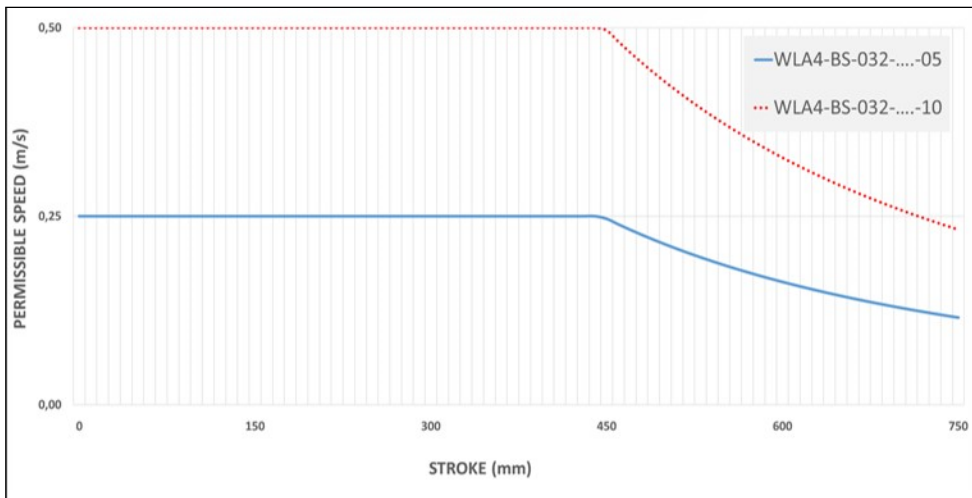

Maximum Force/Stroke

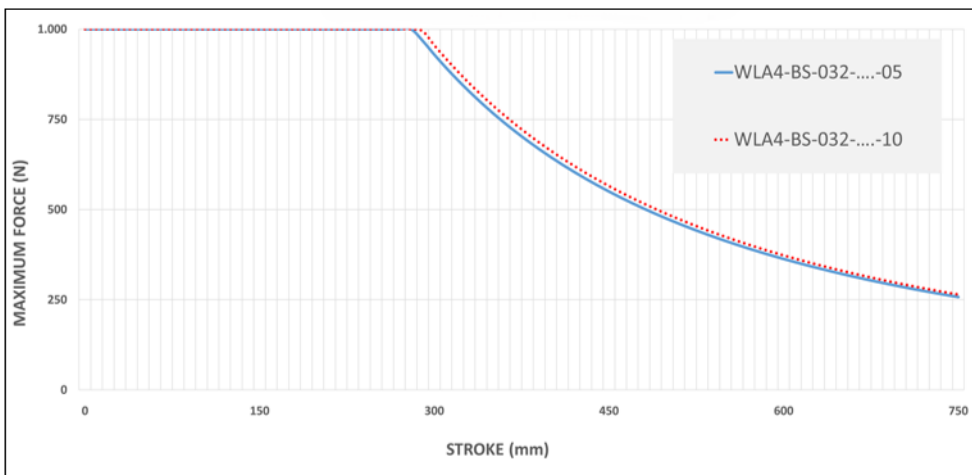

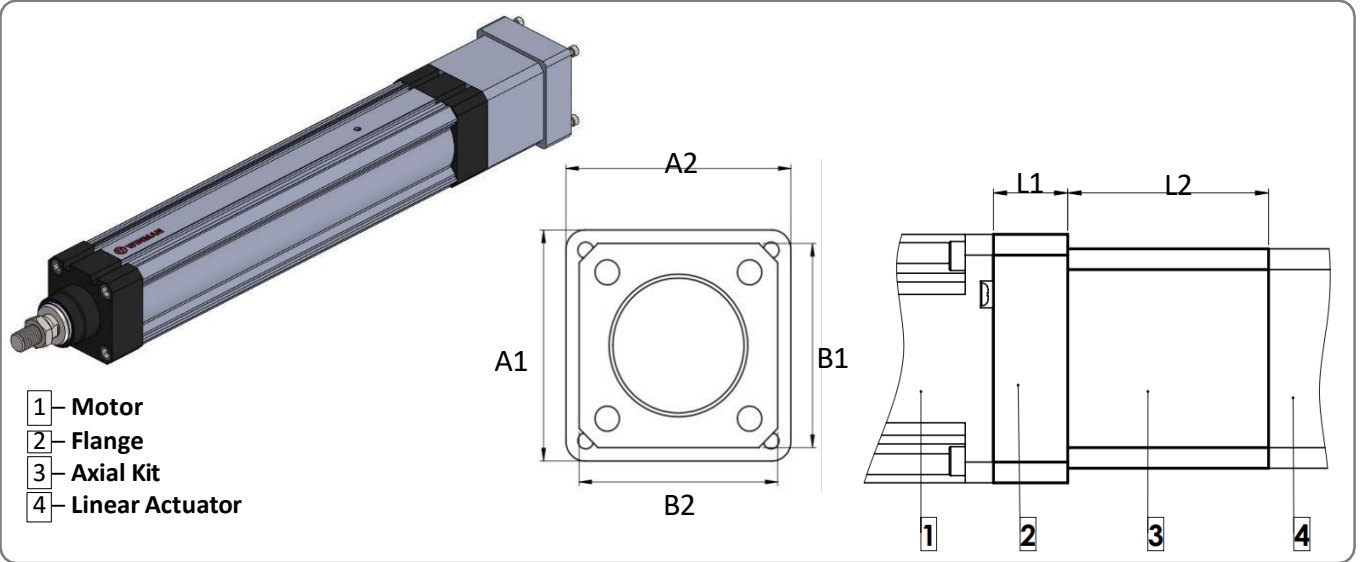
WDAK Axial Mounting Kit
WDAK Technical Drawing

Size	A1	A2	B1	B2	L1	L2
032	58	58	45	45	16	40

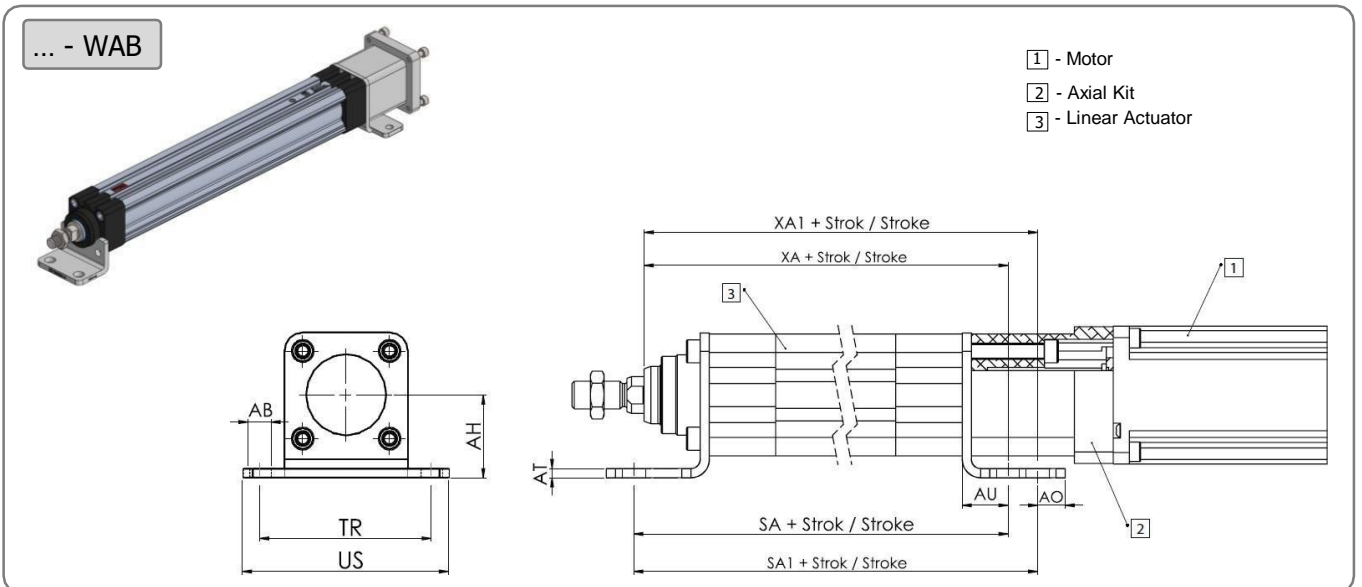
WDAK Axial Mounting Kit

Size	ØAB	AH	AO	AT	AU	SA	SA1	TR	US	XA	XA1
032	7	32	12	5	20	176	-	65	79	177,5	-

WDAK Axial Mounting Kit
WDAK Flansh Mounting

... - WFB

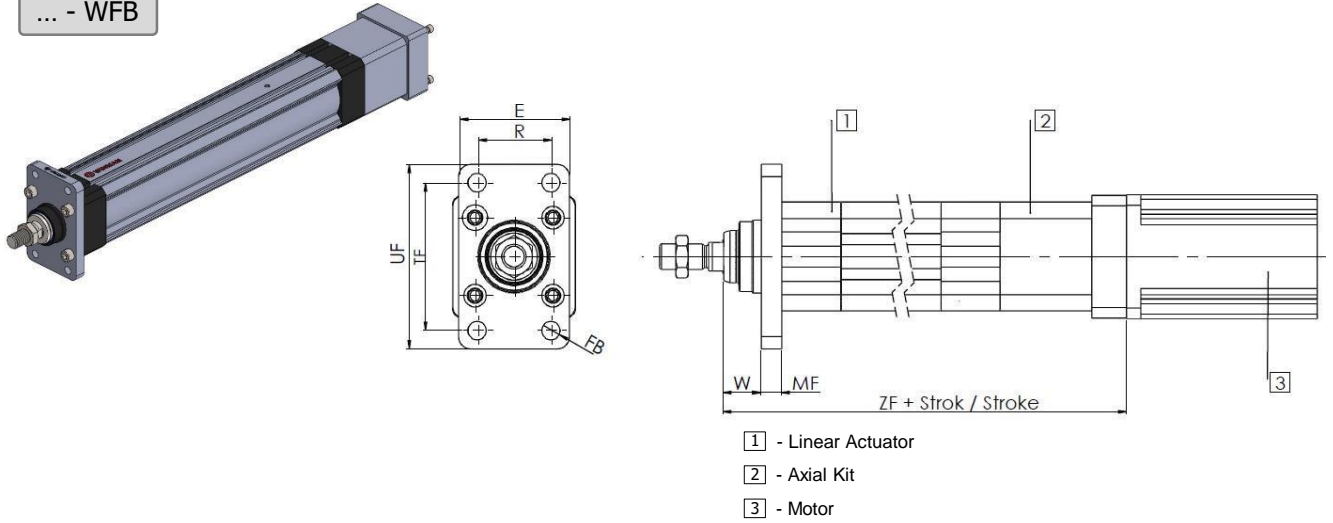

Size	E	FB	MF	R	TF	UF	W	ZF
032	45	7	10	32	64	80	11,5	214

WDAK Axial Mounting Kit

... - FTC

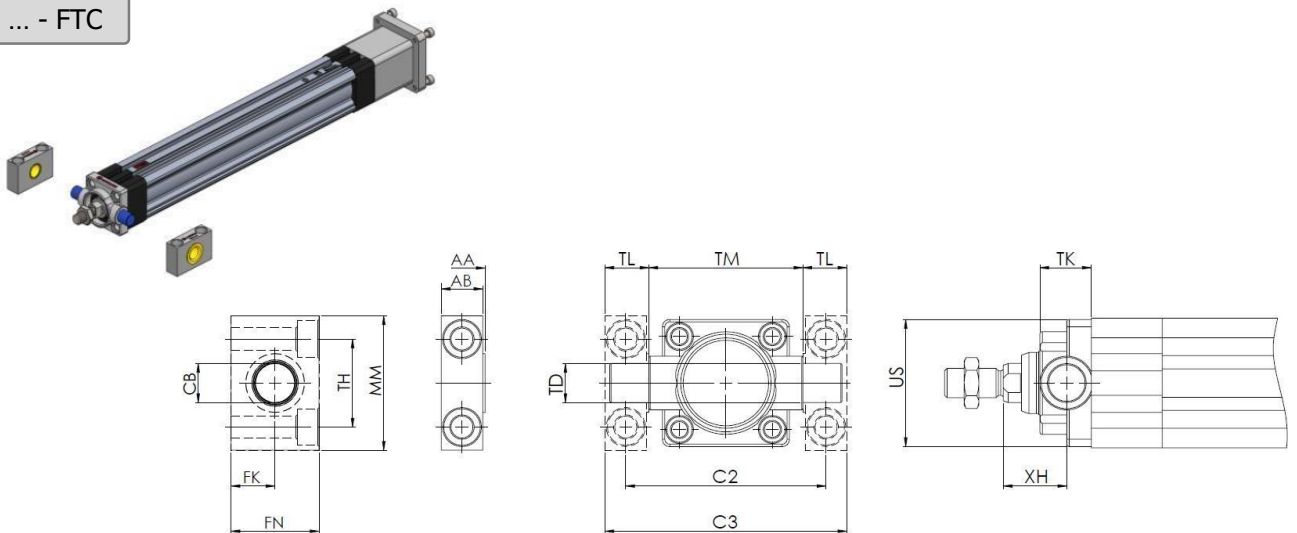

Size	AA	AB	C2	C3	CB	FK	FN	MM	TD	TH	TK	TL	TM	US	XH
032	15	14	66	80	12	15	30	46	12	32	19	12	50	46	16,5

WDPK Parallel Mounting Kit

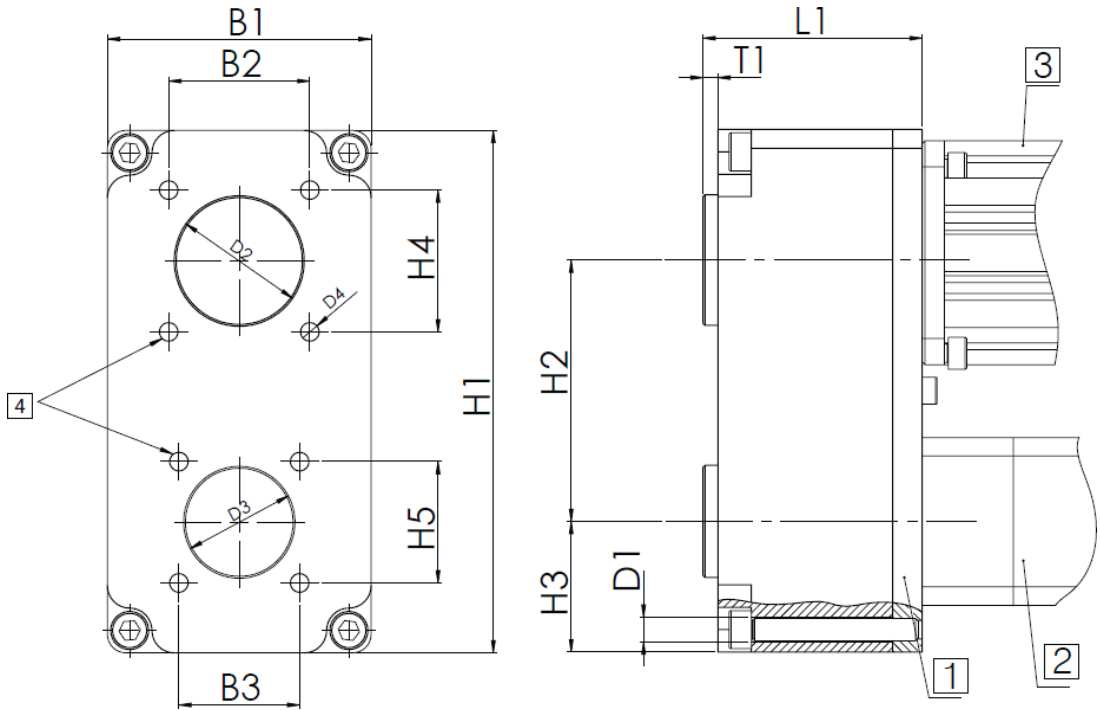
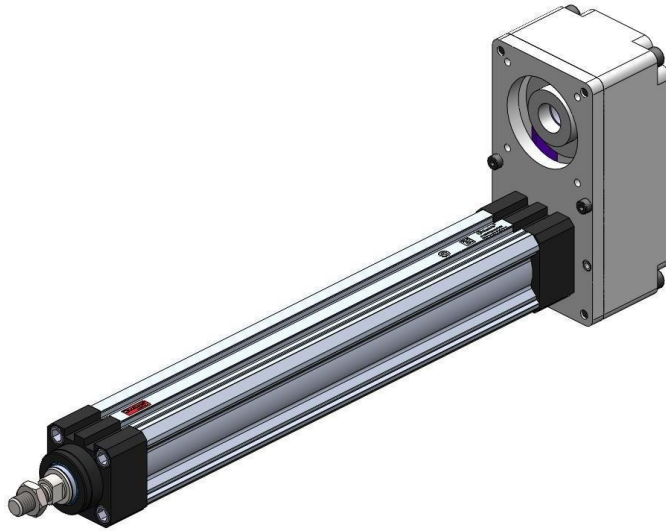

- 1 - Parallel Kit
- 2 - Linear Actuator
- 3 - Motor
- 4 - Mounting Thread

Size	L1	T1	B1	B2	B3	D1	D2	D3	D4	H1	H2	H3	H4	H5
032	59	4	71	38	32,5	M6	35	30	M6	140	70	35	38	32,5

WDPK Axial Mounting Kit
WDPK Flansh Mounting

... - WFB

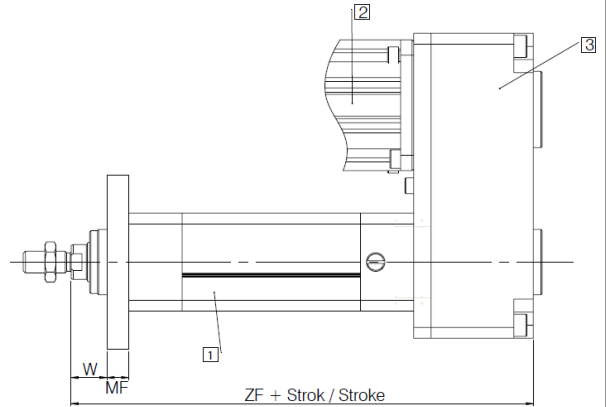
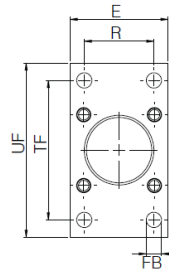

- 1 - Linear Actuator
- 2 - Motor
- 3 - Parallel Kit

Size	E	ØFB	MF	R	TF	UF	W	ZF
032	45	7	10	32	64	80	16,5	212,5

WDPK Foot Mounting

... - WAB

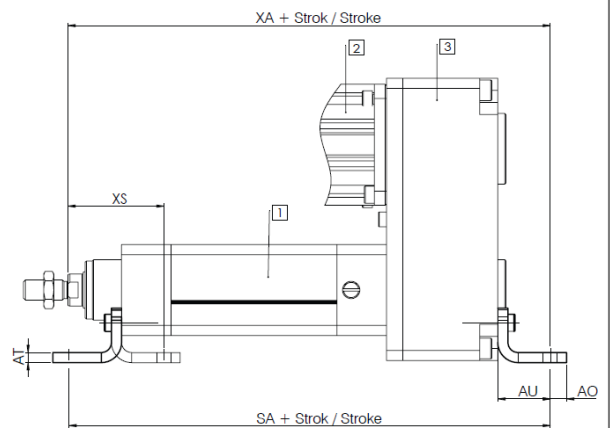
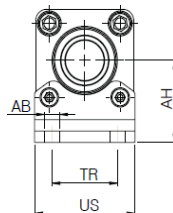
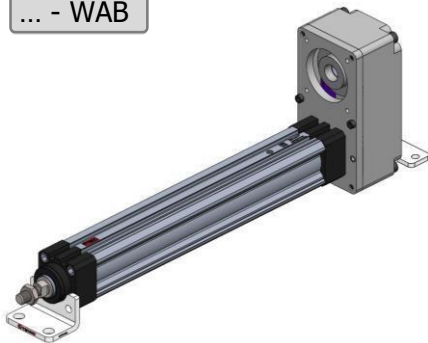

- 1 - Linear Actuator
- 2 - Motor
- 3 - Parallel Kit

Size	AB	AH	AO	AT	AU	SA	TR	US	XA	XS
032	7	36	8	5	26	231	30	46	227	49,5

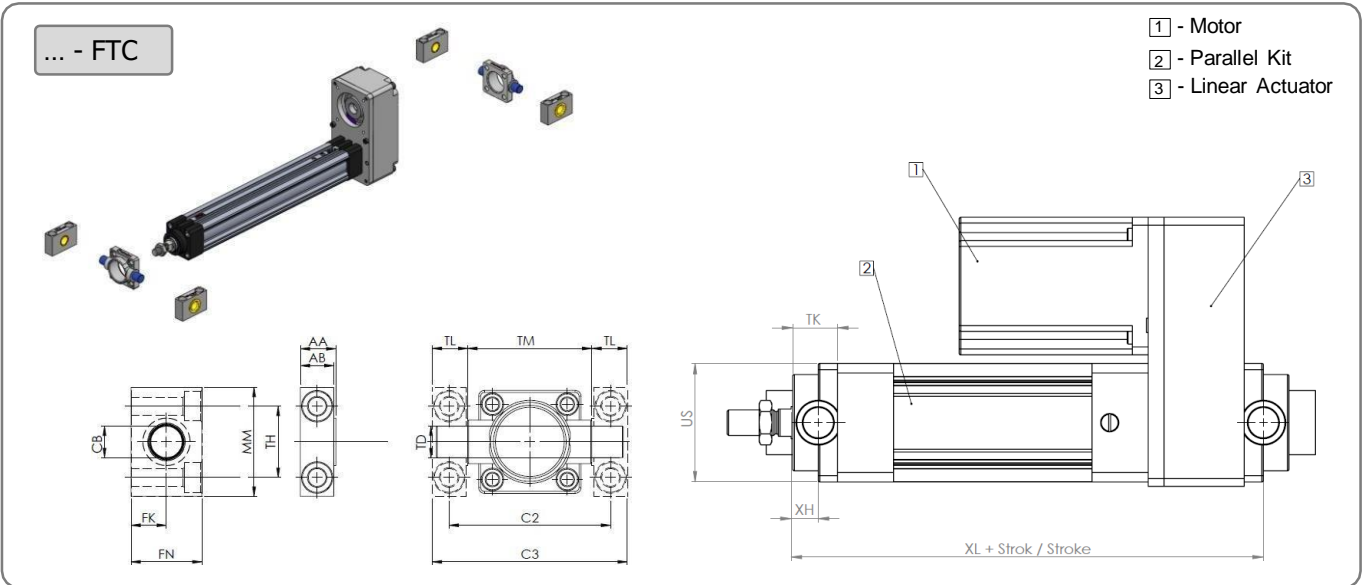
WDPK Parallel Mounting Kit
WDPK Swivel Mounting

Size	AA	AB	C2	C3	C B	FK	FN	MM	TD	TH	TK	TL	TM	US	XH	XL
032	15	14	66	80	12	15	30	46	12	32	19	12	50	46	16,5	209

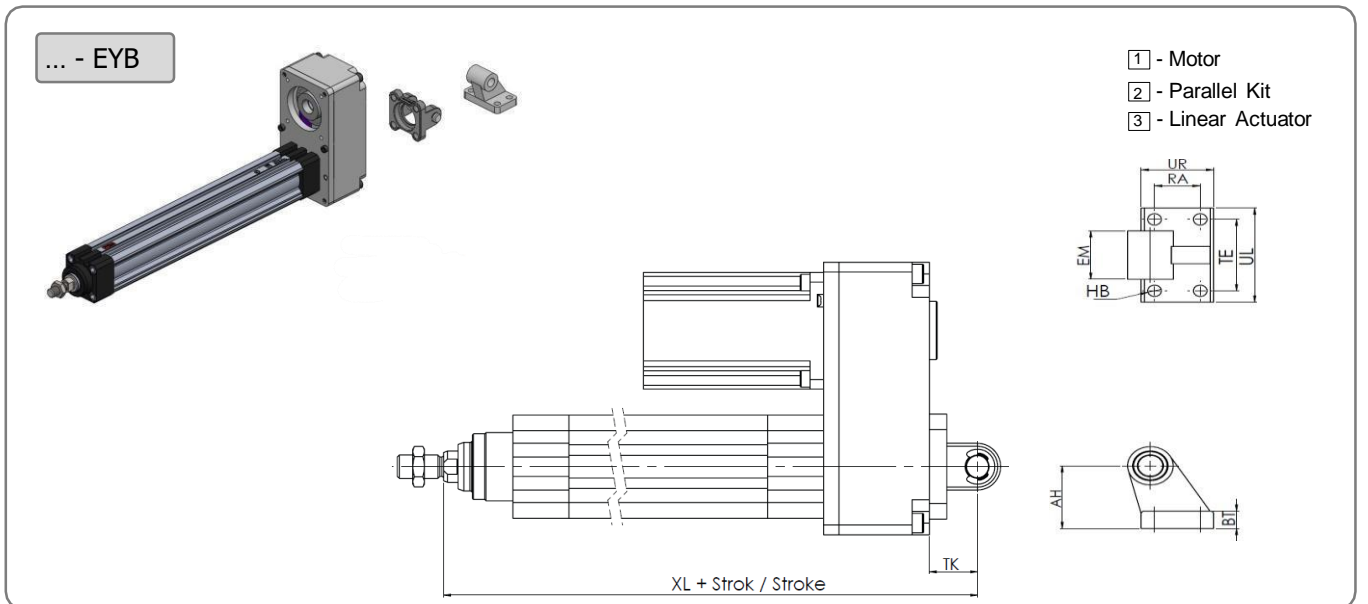
WDPK Foot Mounting

Size	AH	BT	EM	HB	RA	TE	UL	UR	XL
032	32	8	26	6,5	18	38	51	31	229,3

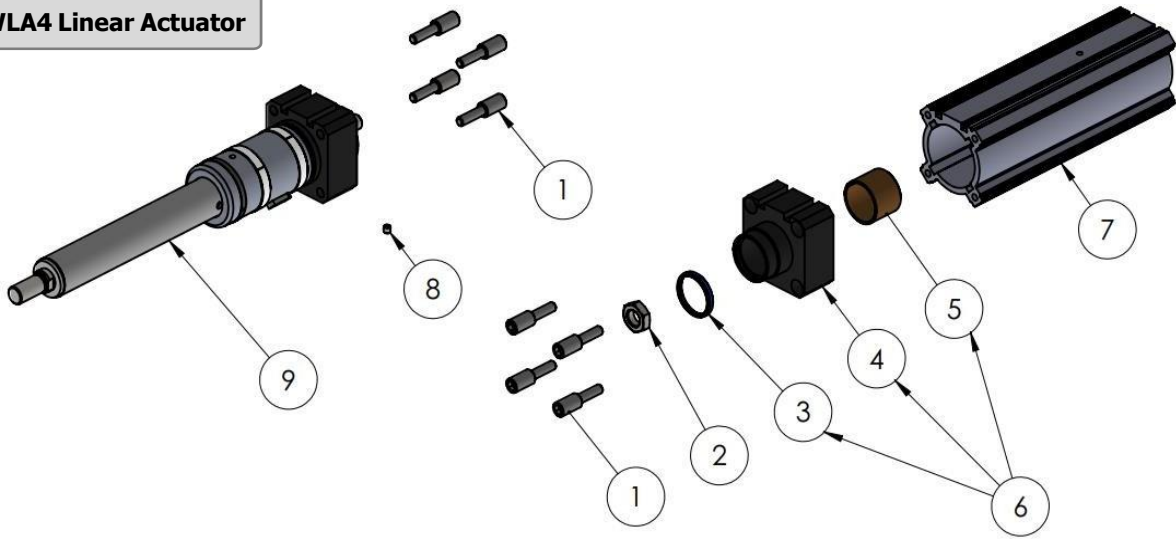
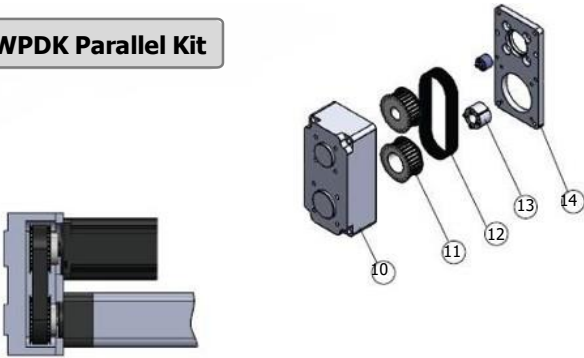
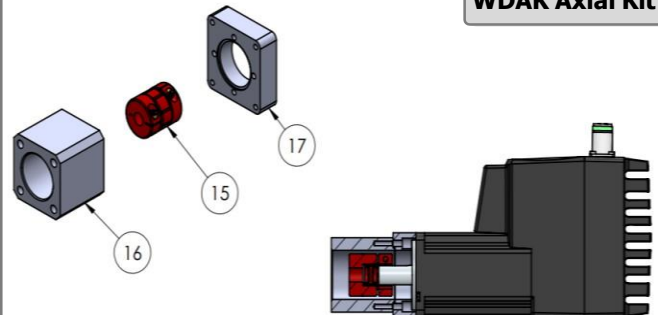
Assembly
WLA4 Linear Actuator

WPKD Parallel Kit

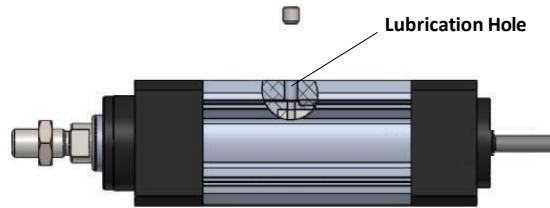
WDAK Axial Kit

Piece	Qty	Part Name	Assembly
1	8	Bolt	Actuator
2	1	Connection Nut	
3	1	Wiper	
4	1	Back Block	
5	1	Bushing	
6	1	Front Block Group Assembly	
7	1	Profile	
8	1	Nipple	Parallel Mounting
9	1	Ball Screw Group Assembly	
10	2	Parallel Kit Cover	
11	1	Timing Belt Pulleys	
12	1	Toothed Belt	
13	1	Taper Bushing	Axial Mounting
14	1	Parallel Kit Cover	
15	1	Coupling	
16	1	Bellhousing	
17	1	Flansh	

Maintenance

Basic lubrication is done in-factory before shipment.

Bearings of the ball screw have been lubricated for life and will not require in-service lubrication under normal operating conditions.

The profile of the linear actuator has port on the top side for access to the lube on the ball nut.

Re-lubrication should be carried out if the defined travel distance is completed or 400 operating hours are reached first. At the end of 2 years, it must be re-lubricated even if the travel distance and working hours are not reached.

For lubrication; set linear actuator to zero stroke position. Remove the grubs in the lubrication port lubricate the amount indicated in the table and replace the glue after lubrication, move the linear actuator at least three times along the stroke distance. the travel speed must not exceed 10 mm / s.

Linear actuators must be lubricated with suitable grease.

Lithium soap grease should be used.

Caution: Do not use grease containing graphite or MoS!

Lubrication quantity is provided in table by normal operating conditions.

Normal Working Conditions

Note : The lubrication quantity specified in the table is valid for normal operating conditions. The lubrication quantity may vary in different operating conditions. Get information for the lubrication quantity in different working conditions.

Ambient Temperature	°C	10 ~ 40
Speed	m/s	≤ 0,4
Screw Rotation Speed	kN	≤ 0,2 C
Load	N	≤ 0,2 P
Stroke	mm	> 60

Lubrication

Actuator Model	WLA4-032	
Lubrication Period	km	250
	h	400
Lubrication Dose	cm	0,6

Our company has the right to modify change images, dimensions and other datas which take place in this catalogue.