

W2CF / Y-Z Axis Connection

W2CF - XX - XXXX - XXXX - X

1
Model

2
Size

3
Stroke Y Axis

4
Stroke Z Axis

5
Motor Position

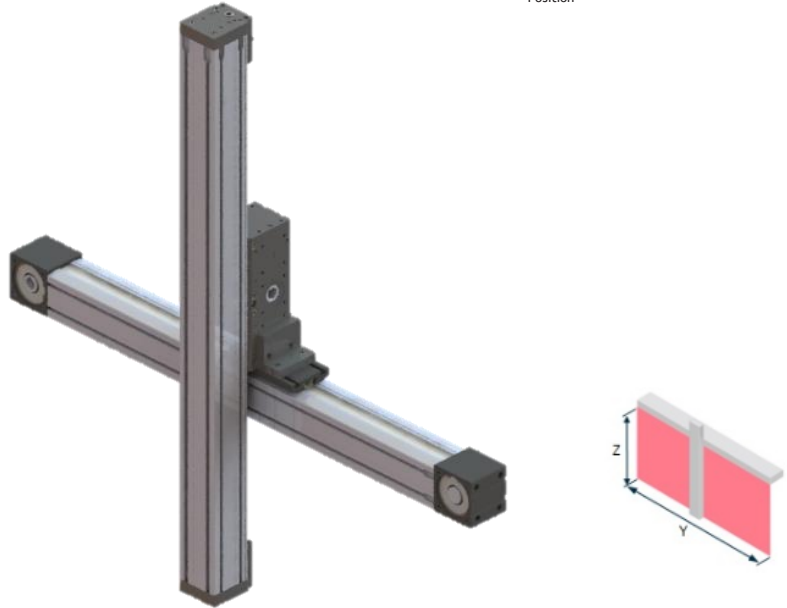

Type	Axis	Linear axis	Lead	Smin (mm)	Smax (mm)
W2CF-01	Y	WMCS-040	90 mm/rev	50 mm	2400
	Z	WMOS-040		50 mm	880
W2CF-02	Y	WMCS-065	140 mm/rev	60 mm	2750
	Z	WMOS-040	90 mm/rev	60 mm	880
W2CF-03	Y	WMCS-065	140 mm/rev	60 mm	2750
	Z	WMOS-065		60 mm	880
W2CF-04	Y	WMCS-080	200mm/rev	60 mm	4750
	Z	WMOS-040	90 mm/rev	50 mm	880
W2CF-05	Y	WMCS-080	200mm/rev	60 mm	4750
	Z	WMOS-065	140 mm/rev	60 mm	880
W2CF-06	Y	WMCS-080	200 mm/rev	60 mm	4750
	Z	WMOS-080		60 mm	880

Technical Drawing

W2CF WDAK - Mounting Kit

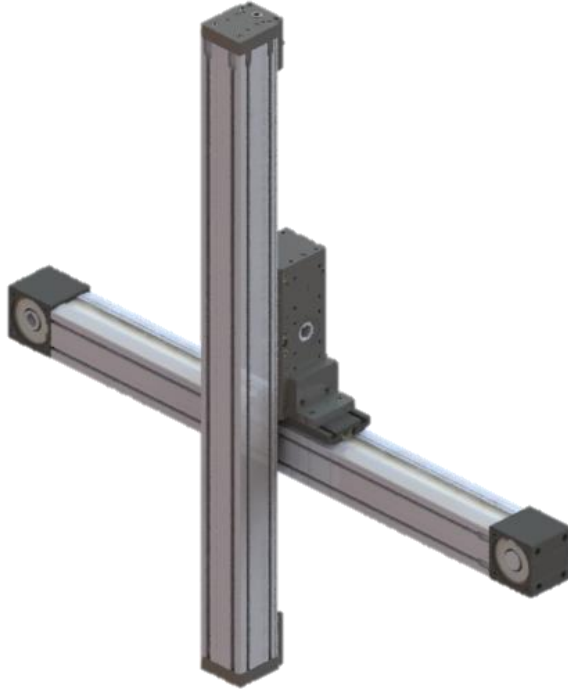

W2CF-XX-XXXX-XXXX-0

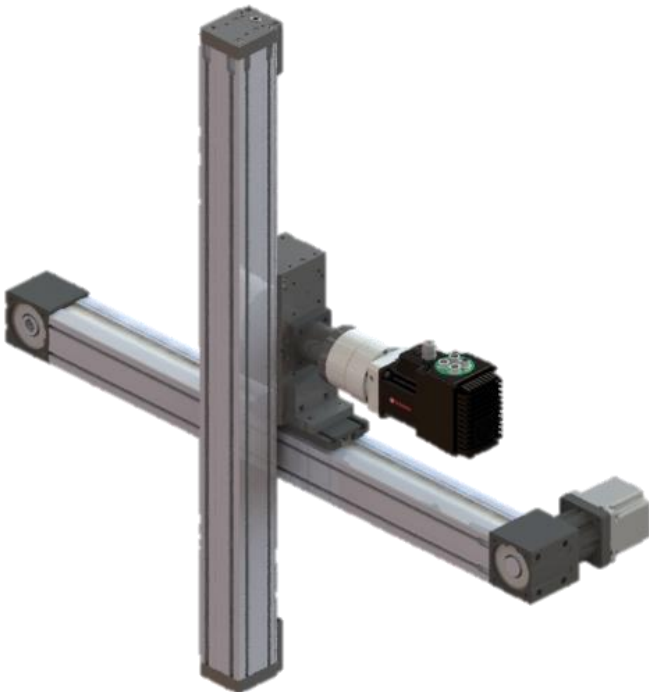

W2CF-XX-XXXX-XXXX-R

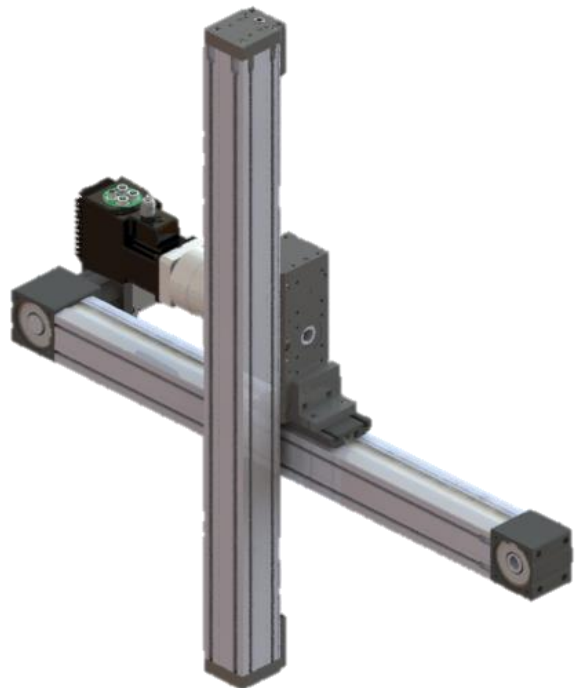

W2CF-XX-XXXX-XXXX-L

W2CA / X-Y Axis Connection

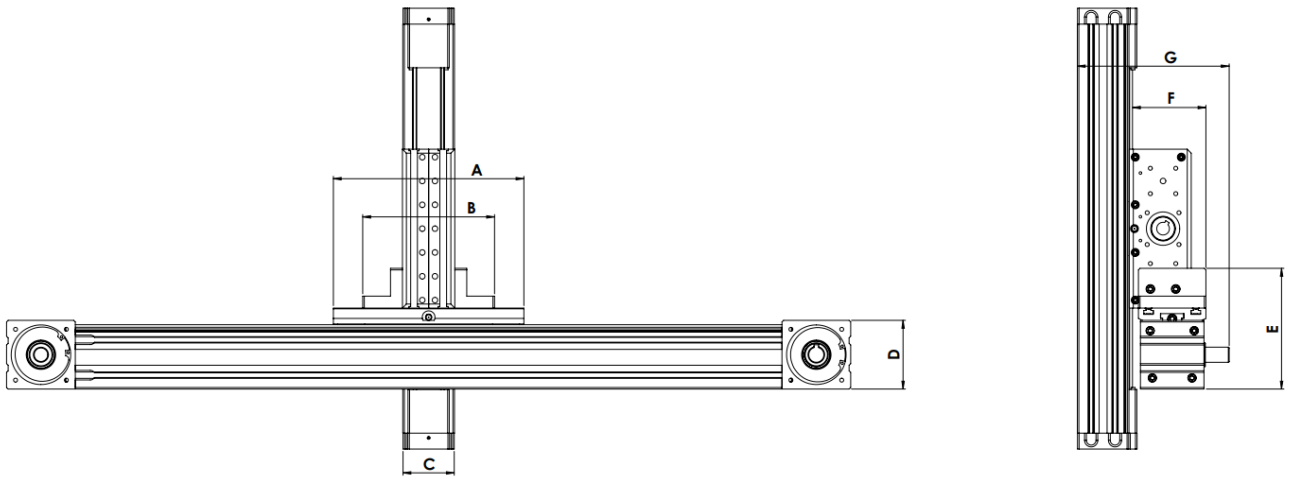

	AXIS	LINEAR AXIS
W2CF-01	Y	WMCS-040
W2CF-01	Z	WMOS-040
W2CF-02	Y	WMCS-065
W2CF-02	Z	WMOS-040
W2CF-03	Y	WMCS-065
W2CF-03	Z	WMOS-065
W2CF-04	Y	WMCS-080
W2CF-04	Z	WMOS-040
W2CF-05	Y	WMCS-080
W2CF-05	Z	WMOS-065
W2CF-06	Y	WMCS-080
W2CF-06	Z	WMOS-080

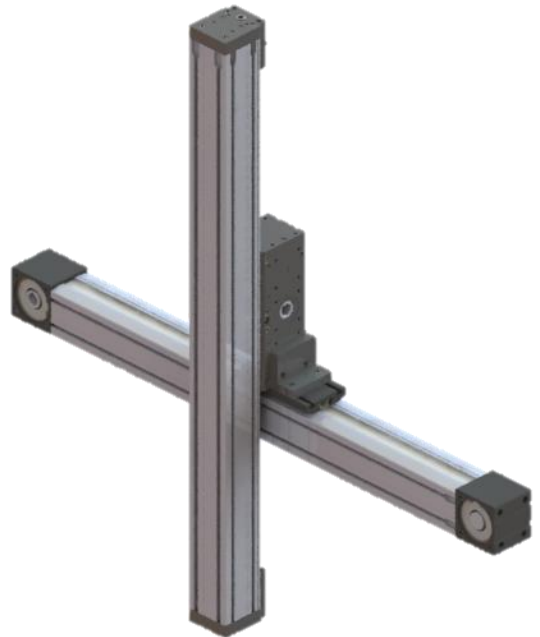

TYPE	A	B	C	D	E	F	G
W2CF-01	116	99	40	43,5	77	66	128,5
W2CF-02	190	142	40	70	119	73,5	147
W2CF-03	190	146	65	70	150	74	174,5
W2CF-04	240	112	40	86,5	127	97	168,5
W2CF-05	240	166	65	86,5	152	92,5	191,5
W2CF-06	240	182	80	86,5	167	94,5	209

W2CF Assembly Parts

W2CF ASSEMBLY PARTS

	CODES	DETAIL VIEW
<p>W2CF-01 ASSEMBLY PARTS</p>	<p>200652</p>	
<p>W2CF-02 ASSEMBLY PARTS</p>	<p>200649</p>	
<p>W2CF-03 ASSEMBLY PARTS</p>	<p>200646</p>	
<p>W2CF-04 ASSEMBLY PARTS</p>	<p>200638</p>	
<p>W2CF-05 ASSEMBLY PARTS</p>	<p>199840</p>	
<p>W2CF-06 ASSEMBLY PARTS</p>	<p>199829</p>	