

VE-...-150-114N-100GAS-...

SOLENOID PILOT OPERATED VALVE, POPPET 2-WAY CARTRIDGE STYLE

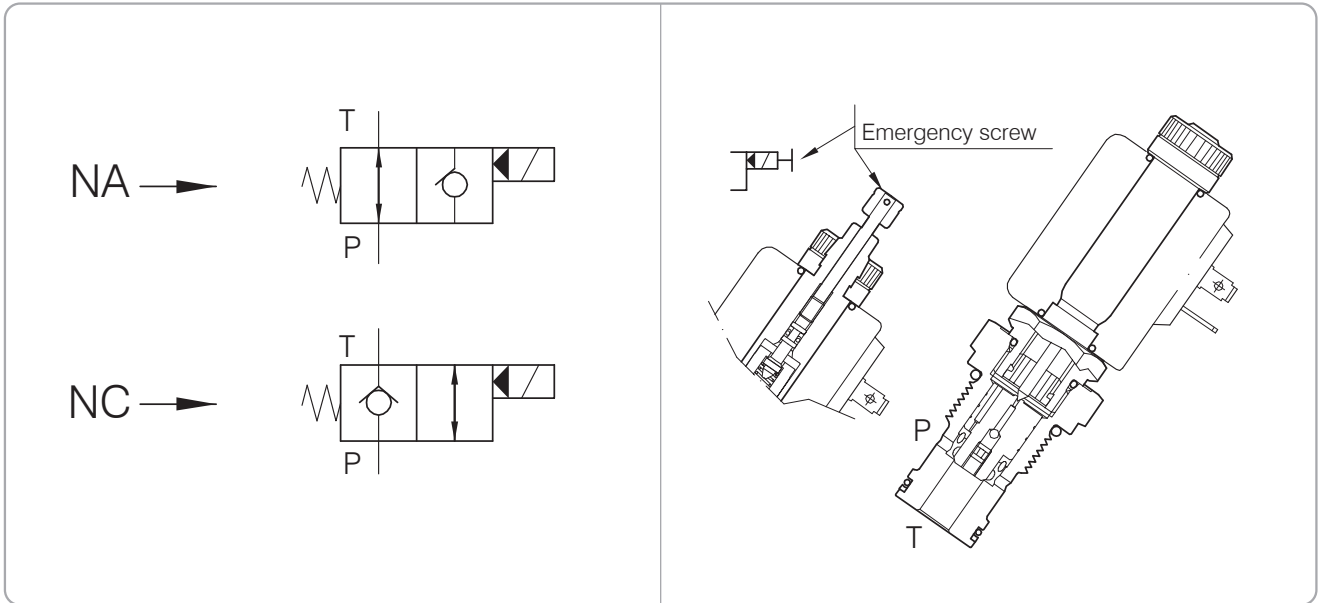

Performance

Rated size	DN 11.5
Min/Max flow-rate	1/150 l/min
Max pressure	300 bar - 4350 PSI
Min. operating voltage	90% of nominal tension
Room temperature	-30°C + 50°C
Oil temperature	-30°C + 80°C
Recommended filtration	25 micron
Tightening torque	47 Nm
Weight	0.390 Kg

Performance Details

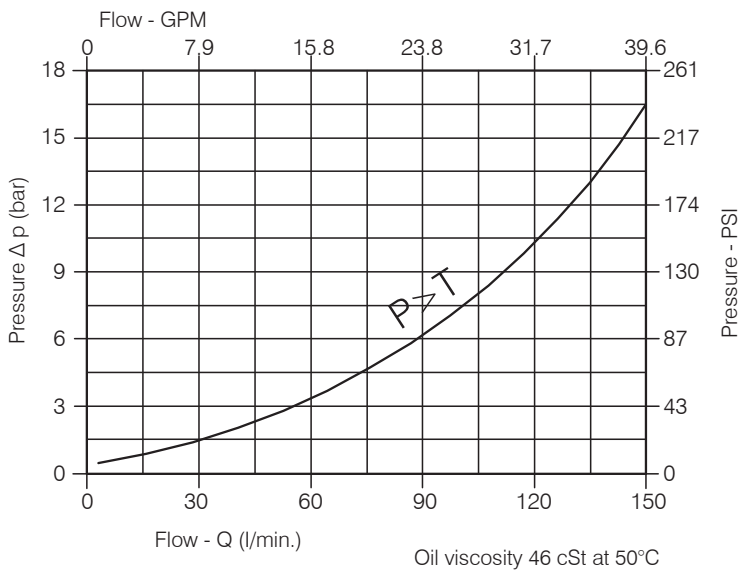

WARNING:

NA cartridges (normally open): all the NA cartridges are designed to work with D.C. power supply. To work with A.C. power supply you have to use a RAC solenoid, which works with rectified power supply, and a connector with rectifier.
 Coils: the power consumption at the starting for coils working in D.C. power supply is about 3,5 times higher than the normal operating power consumption.

VE...-150-114N-100GAS...

Hydraulic valves and integrated components

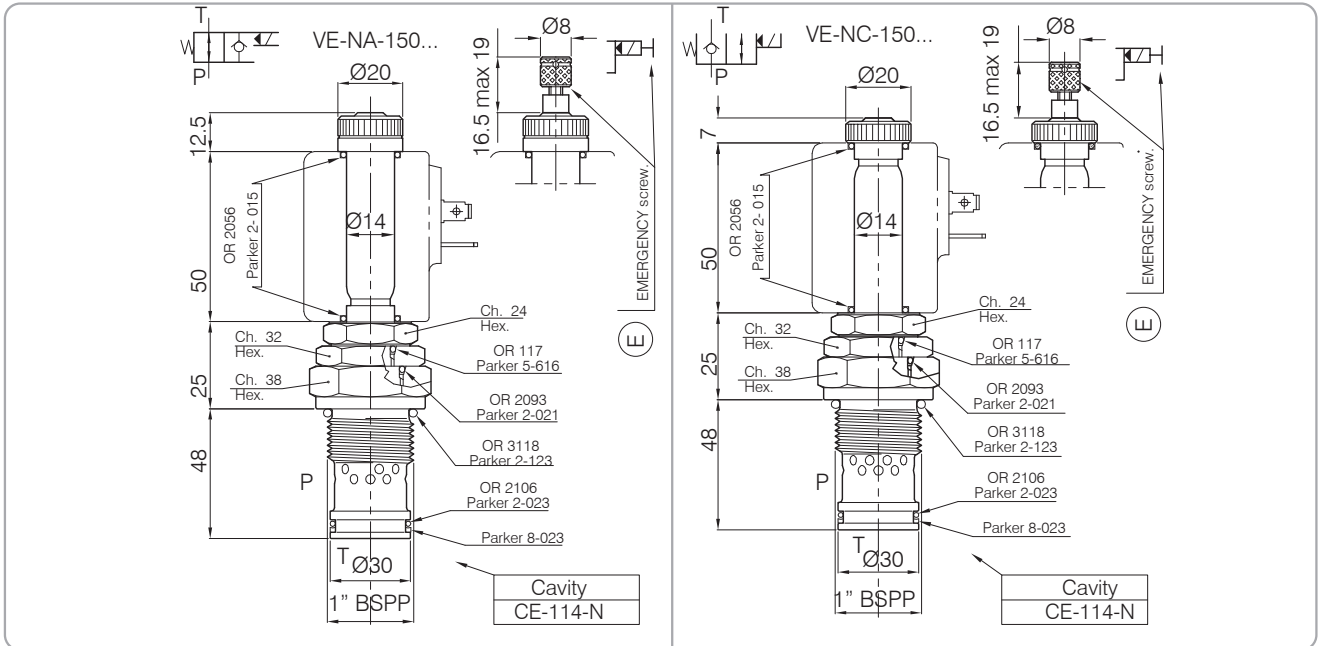

Cavity CE.114.N

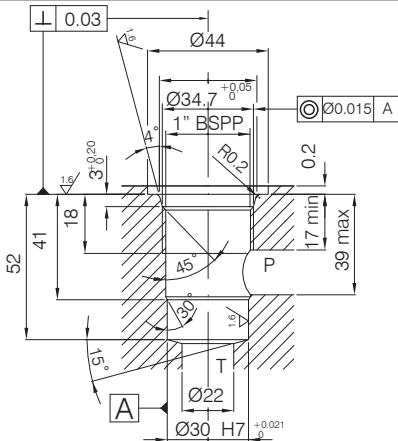

The valve seat should be perfectly tooled

Dimensions

Model Number	Cavity	Notes	Coil See page	Body See page
556	CE-114-N	Normally open	37	43
557	CE-114-N	Normally closed	37	43

Ordering Code



Model Number
556
557

Emergency screw
O Standard
E Emergency screw