

VD-CTP-03

PUMP UNLOADING VALVE WITH ADDITIONAL REFIL

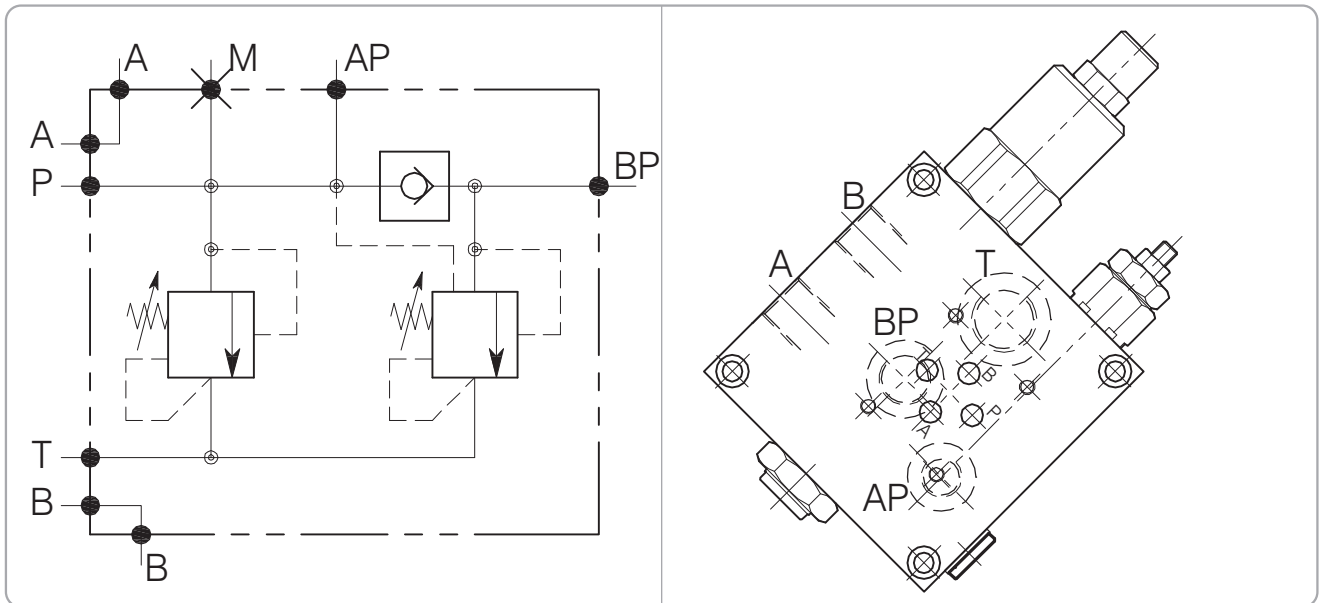

Performance

Rated size	DN 10
Max flow-rate	60 l/min - 15 GPM
Max working pressure	350 bar - 5075 PSI
Max setting pressure	350 bar - 5075 PSI
Room temperature	-30°C + 50°C
Oil temperature	-30°C + 80°C
Recommended filtration	30+50 micron
Weight	

Typical Circuit Example

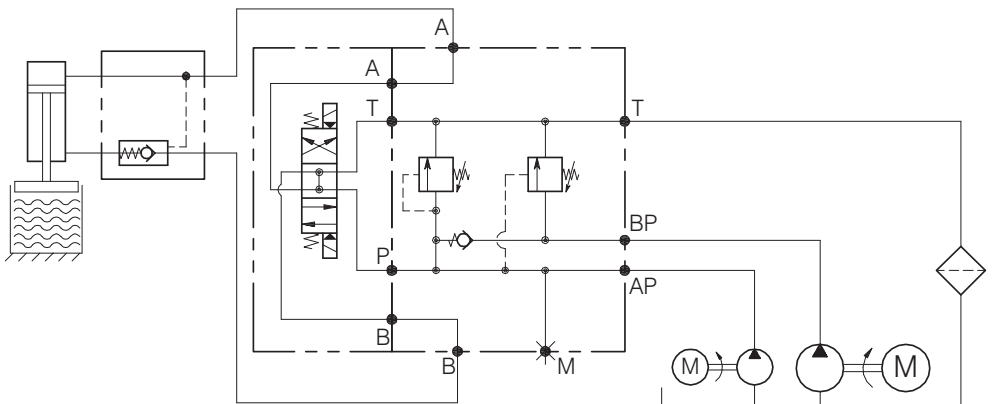

VD-CTP-03

Hydraulic valves and integrated components

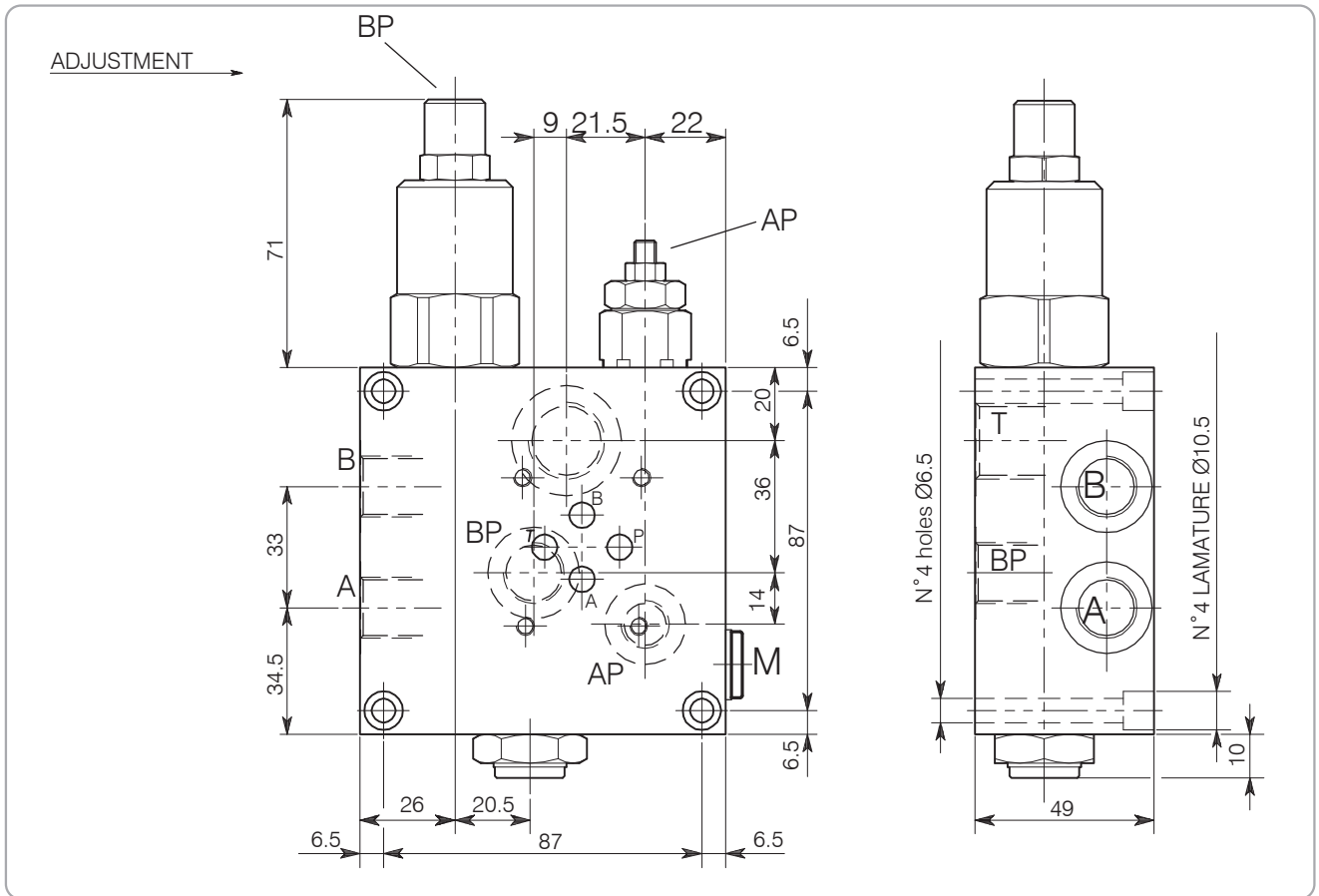

Dimensions

Setting Range			Port size T GAS (BSPP)	Port size A-B- BP GAS (BSPP)	Port size AP- M GAS (BSPP)	Rated size DN	Max flow-rate l/min - GPM
677	676	675	1/2"	3/8"	1/4"	10	60-15

Ordering Code

2 • 6 7 7 • 0 • X • 0

Setting Range			
(AP) 677	(AP) 676	(AP) 675	(BP) 675
Setting range 20÷350 bar (yellow spring)	Setting range 10÷210 bar (yellow spring)	Setting range 5÷100 bar (yellow spring)	Setting range 10÷90 bar (yellow spring)
Std. bar setting (Q=5 l/1') 280 bar	Std. bar setting (Q=5 l/1') 140 bar	Std. bar setting (Q=5 l/1') 70 bar	Std. bar setting (Q=5 l/1') 40 bar