

SANG-A GPW Serisi Redüksiyon Tipi Ye Bağlantılar

Reducer Y

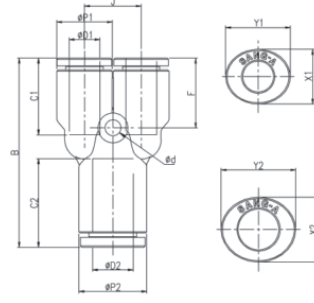

Boyutlar

MODEL [ØD-T] Tube: (Metric) - Thread: (R)

MODEL	ØD1	ØD2	ØP1	ØP2	B	C1	C2	Ød	F	J	X1	Y1	X2	Y2	Orifice (Ømm)	W.G(g)	Q'ty/ inbox
GPW 0604	4	6	9	11.2	32.5	14.5	15.5	3.2	13.2	9.3	8.6	10.8	11	13	2.6	5.1	100
GPW 0804	4	8	11.2	13.6	37.7	14.5	17.8	3.2	13.7	11.4	8.6	10.8	13	15	2.6	12.3	50
GPW 0806	6	8	11.2	13.6	38.5	15.5	17.8	3.2	14.1	11.4	11	13	13	15	4.1	8.2	50
GPW 1006	6	10	13.6	16.3	42.6	15.5	19.4	3.2	17.2	14.2	11	13	16	18.5	4.1	19.8	25
GPW 1008	8	10	13.6	16.3	43.2	17.8	19.4	3.2	17.8	14.2	13	15	16	18.5	6.4	12.6	25
GPW 1208	8	12	16.3	19.7	50.5	17.8	22.4	4.2	17.6	17	13	15	19.5	22.5	6.4	29.4	25
GPW 1210	10	12	16.3	19.7	50.9	19.4	22.4	4.2	18	17	16	18.5	19.5	22.5	7.0	20.4	25