

AIRTAC 6D Haberleşmeli Pnömatik Valfler/ AIRTAC 6D Communication Pneumatic Valves

Manual Lock Design

1. Manual push does not automatically lock, used for valve installation and debugging.
2. Use caution, prior to activating manual override.
3. With the correct size screw driver: gently press and turn to lock (Torque: 0.1N.m)

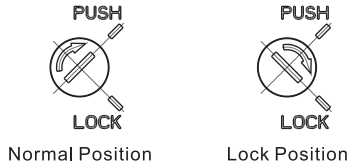

Adaptor design of pilot valve

Easy to install with stable signaling, decreases risk during manual wiring

Consolidate Input

The D-SUB25PIN cable, simplifies wiring process and enhances risk-resisting function.

Multi-series and Multi-port types are optional

6D0500, 6D100, 6D200 series ;
Φ4、Φ6、Φ8、Φ10ports for options.

Series/Ports(A\B ports)	Φ4	Φ6	Φ8	Φ10
6D0500	•	•		
6D100	•	•	•	
6D200			•	•

Dual Centralized inlet ports

Centralized inlet, convenient piping, saving installation space.

Series	6D0500	6D100	6D200
Ports(P)	Φ8	Φ10	Φ12

Dual Centralized outlet ports

Centralized exhaust, convenient piping, saving installation space.

Series	6D0500	6D100	6D200
Ports(R)	Φ8	Φ10	Φ12

Manifold design

It is convenient and flexible to disassemble and replace.

DIN rail compatibility

Manifold is compatible with DIN standard rail.
6D integrated valve can be fixed at any position of rail by stop screw.

Diverse installation

With four bolts, it can be fixed anywhere on panel.

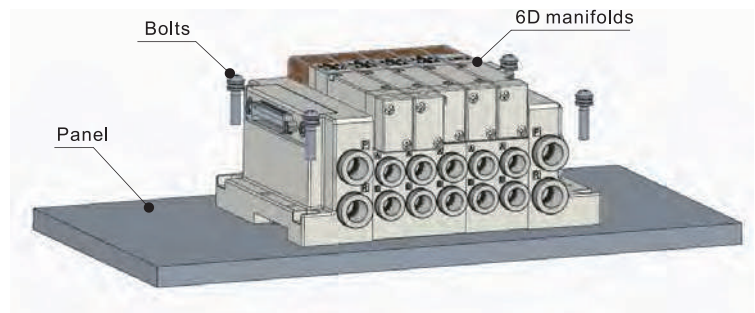
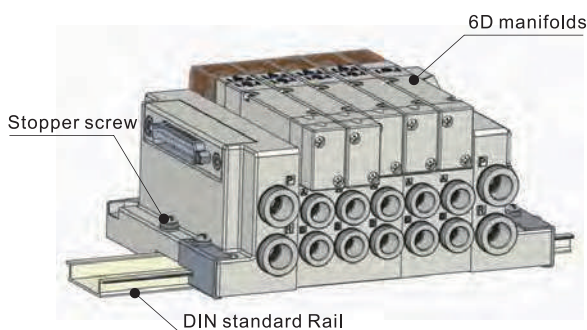

AIRTAC 6D Haberleşmeli Pnömatik Valfler/ AIRTAC 6D Communication Pneumatic Valves



Specification

Model	6D0500	6D100	6D200
Fluid	Air(to be filtered by 40µm filter element)		
Acting	Pilot		
Operating pressure	5/3 way	0.2~0.8MPa(29~114psi)	
	Others	0.15~0.8MPa(21~114psi)	
Proof pressure	1.2MPa(175psi)		
Temperature	-20~70°C		
Type of inlet and exhaust	Centralized inlet and exhaust		
Numbers of station	Single solenoid valves	3-21 stations	
	Dual solenoid valves	3-21 stations [Note1]	
Port size	A, B ports	Φ4/Φ6 tube fitting	Φ4/Φ6/Φ8 tube fitting
	P, R ports	Φ8 tube fitting	Φ10 tube fitting
Electrical entry	Terminal , 25pinD-SUB		

Note1: On 3 to 18 station valve banks, only the first 6 positions can have double solenoid valves(2 or 3 positions)
On 19 to 21 station valve banks, only the first 3 positions can have double solenoid valves(2 or 3 positions)

Symb • I

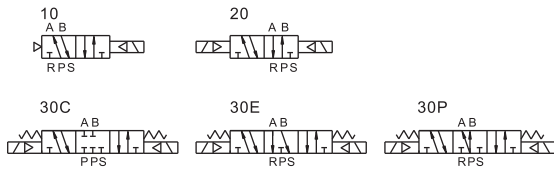

Product feature

1. Centralized inlets, outlets and signal input(25pin D-SUB) make it highly simplifies installation and reduces risk during mounting.
2. Flexible combination for various applications.
3. Convenient installation, can be fixed on panel or DIN rail without other accessory.
4. 2 position and 3 position valves can be installed on the same manifold without further accessories.
5. Affiliated manual devices are equipped to facilitate installation and debugging.
6. Low starting voltage and long service life.

Coil specification

Item	Specification	
Standard voltage	DC24V	DC12V
Scope of voltage	DC : ±10%	
Power of consumption	DC : 0.9W	
Protection	Dustproof	
Temperature classification	F Class	
Electrical entry	Terminal	
Activating time	0.05 sec and below	

Flow chart

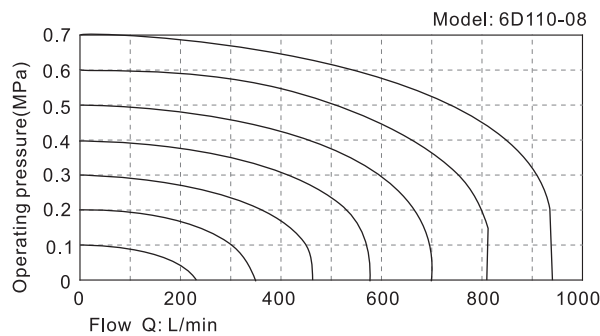
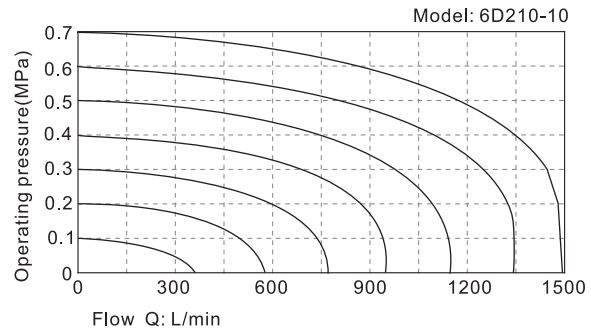
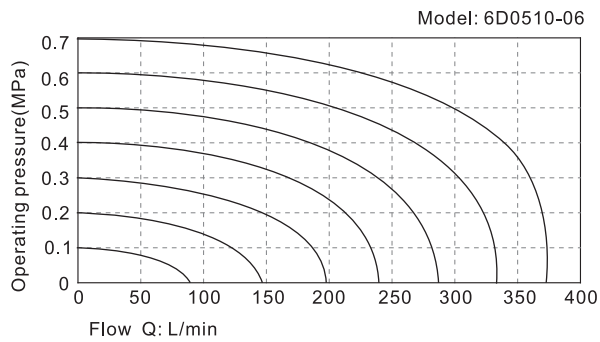

Flow rate data obtained from the AirTAC R&D Lab.



AIRTAC 6D Haberleşmeli Pnömatik Valfler/ AIRTAC 6D Communication Pneumatic Valves

Manifold ports Ordering Code (With Valves)

6D W 1H 8F-J06 B S1 D2 C2 E2 P1 □



Without communication module Without communication module With communication module

① Valve type	Blank: Standard type W: Valve with double solenoid manifold(7~12 stations)		
② Model	05H: 6D0500 Series integrated Solenoid valve	1H: 6D100 Series integrated Solenoid valve	2H: 6D200 Series integrated Solenoid valve
③ Number of stations	3F: 3 stations 4F: 4 stations 21F: 21stations		
④ Port size(A/B Port)	J04: Φ4 tube fitting J06: Φ6 tube fitting	J04: Φ4 tube fitting J06: Φ6 tube fitting J08: Φ8 tube fitting	J08: Φ8 tube fitting J10: Φ10 tube fitting
⑤ Standard voltage	B:DC24V F:DC12V		
⑥ Single solenoid 5/2 way	Blank: No	S1: 1 piece S2: 2 pieces S21: 21 pieces	
⑦ Double solenoid 5/2 way	Blank: No	D1: 1 piece D2: 2 pieces D6: 6 pieces	
⑧ Double solenoid 5/3 way closed center	Blank: No	C1: 1 piece C2: 2 pieces C6: 6 pieces	
⑨ Double solenoid 5/3 way exhaust center	Blank: No	E1: 1 piece E2: 2 pieces E6: 6 pieces	
⑩ Double solenoid 5/3 way pressure center	Blank: No	P1: 1 piece P2: 2 pieces P6: 6 pieces	
⑪ Type of communication module	Blank: Without communication module CPN1: Profinet+PNP CPN2: Profinet+NPN CEN1: EtherNet/IP+PNP CEN2: EtherNet/IP+NPN		

Ordering code instruction:

1. Fill in spec, number of stations, port size, voltage in order code accordingly.
2. Valve installation sequence : start from D-SUB side.
3. Valve installation sequence : (1) Double solenoid 5/3 way(C→E→P). (2) Double solenoid 5/3 way. (3)Single solenoid.
4. For empty position, please install provisional block.
5. 0500 series in/outlet ports (P/R) is Ø8, 100 series in/outlet ports (P/R) is Ø10, 200 series in/outlet ports (P/R) is Ø12
6. Less than 8 stations(inclusive):come with 1 plug type silencer and 2 plugs; More than 8 stations: come with 2 plug type silencers and 1 plug.
7. Total numbers of valves must be ≤21
8. For station 3-18 of standard type, total numbers of ⑥+⑦+⑧+⑨ must be ≤6 ; station 19-21 of standard type, total numbers of ⑥+⑦+⑧+⑨ must be ≤3.
9. When total number of double solenoid valves ≥7 is required, only 6DW series is optional;
10. For 6DW series: total number of double solenoids+single solenoids must be ≤12;
11. When only 3/4/5/6 stations of double solenoids are required, it is sufficient to select a standard type valve.
12. Other protocols: EtherCAT, IO-Link are estimated to be released in Jan.2023.

Manifold ports Ordering Code (Without Valves)

6D W 1H 8F J06



① Manifold type	Blank: Standard type W: Double solenoid manifold(7~12 stations)		
① Model	05H: 6D0500 Series manifold	1H: 6D100 Series manifold	2H: 6D200 Series manifold
② Number of stations	3F: 3 stations 4F: 4 stations 21F: 21stations		
④ Port size(A/B Port)	J04: Φ4 tube fitting J06: Φ6 tube fitting	J04: Φ4 tube fitting J06: Φ6 tube fitting J08: Φ8 tube fitting	J08: Φ8 tube fitting J10: Φ10 tube fitting

Note:

1. On 3 to 18 station valve banks of standard type only the first 6 positions can have double solenoid valves(2 or 3 positions)
On 19 to 21 station valve banks of standard type only the first 3 positions can have double solenoid valves(2 or 3 positions)
2. Valve installation sequence: start from D-SUB side.
3. 0500 series in/outlet ports (P/R) is Ø8, 100 series in/outlet ports (P/R) is Ø10, 200 series in/outlet ports (P/R) is Ø12
4. Less than 8 stations(inclusive): come with 1 plug type silencer and 2 plugs; More than 8 stations: come with 2 plug type silencers and 1 plug.
5. When total number of double solenoid valves ≥7 is mounted, only 6DW series is optional;
6. For 6DW series: total number of double solenoids+single solenoids can be mounted must be ≤12;
7. When only 3/4/5/6 stations of double solenoids are mounted, it is sufficient to select a standard type manifold.

AIRTAC 6D Haberleşmeli Pnömatik Valfler/ AIRTAC 6D Communication Pneumatic Valves

Solenoid Valve Ordering Code

6D 1 20 B

① ② ③ ④



① Model	6D: 5-port, 2/3-position solenoid valve		
② Code	05: 0500 Series	1: 100 Series	2: 200 Series
③ Valve type	10 : Single solenoid(5/2 Way)	20 : Double solenoid(5/2 Way)	30C : Double solenoid(5/3 way closed center)
	30E : Double solenoid(5/3 way exhaust center)	30P : Double solenoid(5/3 way pressure center)	
④ Standard Voltage	B: DC24V F: DC12V		

Provisional Block Ordering Code

P - 6D100M - R2

① ② ③



① Accessories	P : Accessories		
② Model	6D0500M: 0500 Series	6D100M: 100 Series	6D200M: 200 Series
③ Provisional block code	R2: 6D series Provisional block		

Note:Orders come with screw bolts.

DIN Rail Ordering Code

F - DINX140

① ②



① Accessories	F-DIN: DIN Rail		
② Length of DIN rail	140 : 140mm	175 : 175mm	210 : 210mm1000 : 1000mm

Note: DIN rail add length is 35mm each step.

Dimensions

6D0500

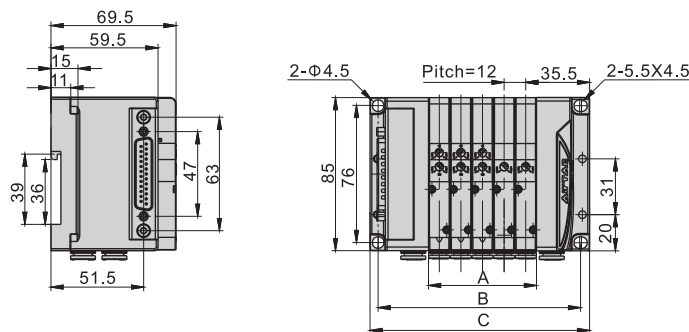

Item\Stations	3F	4F	5F	6F	7F	8F	9F	10F	11F	12F	13F	14F	15F	16F	17F	18F	19F	20F	21F
A	36	48	60	72	84	96	108	120	132	144	156	168	180	192	204	216	228	240	252
B	88.5	100.5	112.5	124.5	136.5	148.5	160.5	172.5	184.5	196.5	208.5	220.5	232.5	244.5	256.5	268.5	280.5	292.5	304.5
C	98	110	122	134	146	158	170	182	194	206	218	230	242	254	266	278	290	302	314



AIRTAC 6D Haberleşmeli Pnömatik Valfler/ AIRTAC 6D Communication Pneumatic Valves

6D100

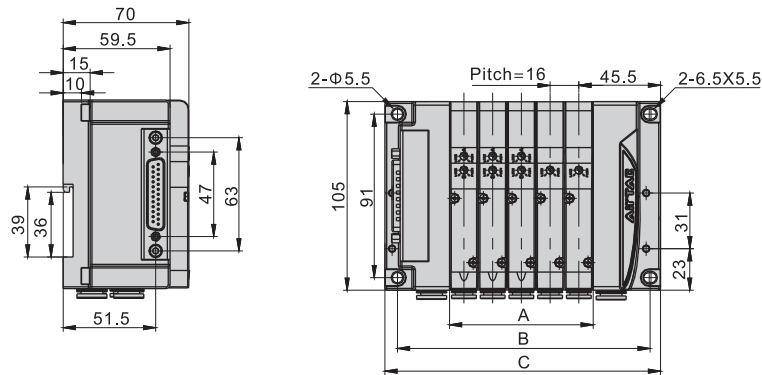

Item\Stations	3F	4F	5F	6F	7F	8F	9F	10F	11F	12F	13F	14F	15F	16F	17F	18F	19F	20F	21F
A	48	64	80	96	112	128	144	160	176	192	208	224	240	256	272	288	304	320	336
B	108.5	124.5	140.5	156.5	172.5	188.5	204.5	220.5	236.5	252.5	268.5	284.5	300.5	316.5	332.5	348.5	364.5	380.5	396.5
C	121.5	137.5	153.5	169.5	185.5	201.5	217.5	233.5	249.5	265.5	281.5	297.5	313.5	329.5	345.5	361.5	377.5	393.5	409.5

6D200

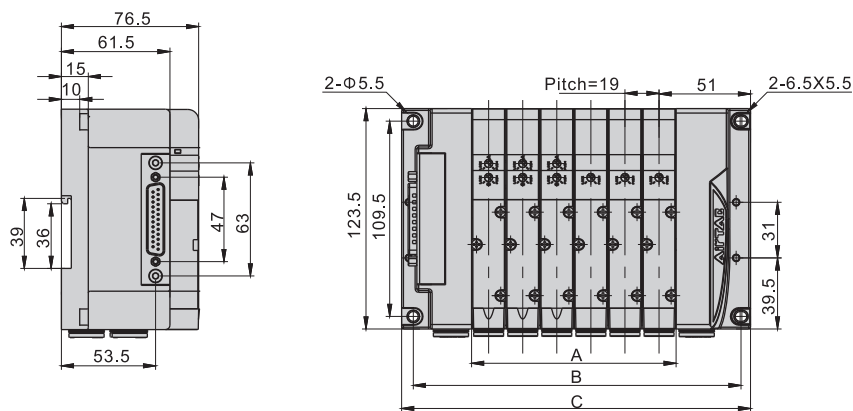

Item\Stations	3F	4F	5F	6F	7F	8F	9F	10F	11F	12F	13F	14F	15F	16F	17F	18F	19F	20F	21F
A	57	76	95	114	133	152	171	190	209	228	247	266	285	304	323	342	361	380	399
B	125.5	144.5	163.5	182.5	201.5	220.5	239.5	258.5	277.5	296.5	315.5	334.5	353.5	372.5	391.5	410.5	429.5	448.5	467.5
C	137.5	156.5	175.5	194.5	213.5	232.5	251.5	270.5	289.5	308.5	327.5	346.5	365.5	384.5	403.5	422.5	441.5	460.5	479.5

Installation and application

1. Two types of installation are available, choose appropriate type based on working environment.

1) Panel mount type

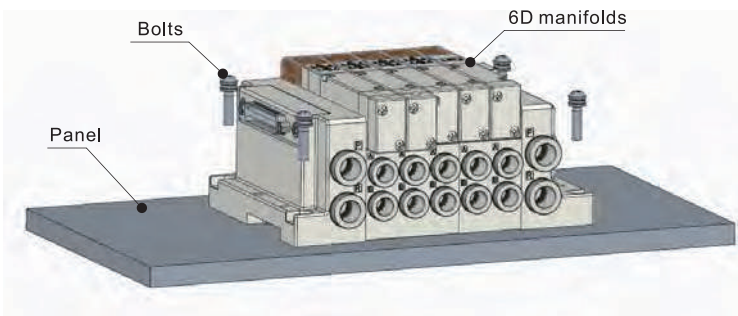

Four counterbore holes for screw bolts, suitable for panel installation.

2) DIN rail mount type

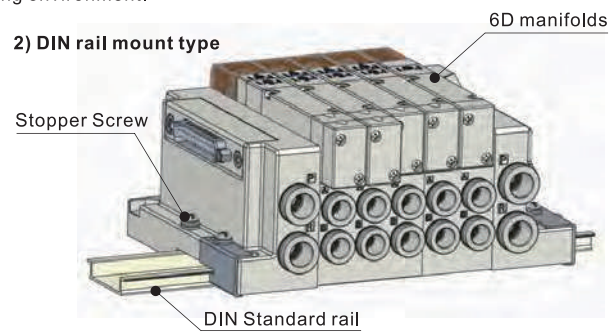

Compatible with standard DIN rail.

6D manifolds can be fixed at any position of rail by stop screw.

2. P/R ports connection: Please select the appropriate tube diameter according to the following specification table.

Series	Port (P)	Port (R)
6D0500	Φ8	Φ8
6D100	Φ10	Φ10
6D200	Φ12	Φ12

3. A/B ports connection: Please select the appropriate tube diameter according to the following specification table.

Series\Ports(A/B ports)	Φ4	Φ6	Φ8	Φ10
6D0500	•	•		
6D100	•	•	•	
6D200			•	•

AIRTAC 6D Haberleşmeli Pnömatik Valfler/ AIRTAC 6D Communication Pneumatic Valves

4. Pin Assignment :

Explanation of 3-18 stations connection pin.

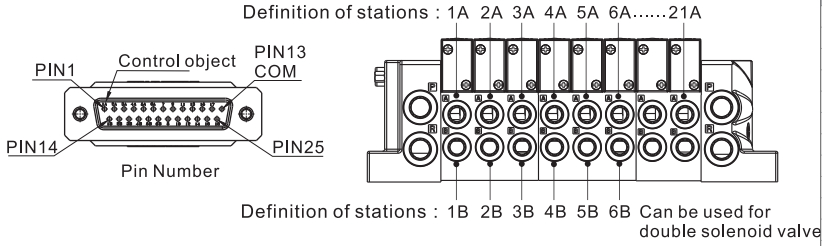

Pin NO.	Polarity		Control object	Pin NO.	Polarity		Control object
	-COM	+COM			-COM	+COM	
1	(+)	(-)	1A	14	(+)	(-)	1B
2	(+)	(-)	2A	15	(+)	(-)	2B
3	(+)	(-)	3A	16	(+)	(-)	3B
4	(+)	(-)	4A	17	(+)	(-)	4B
5	(+)	(-)	5A	18	(+)	(-)	5B
6	(+)	(-)	6A	19	(+)	(-)	6B
7	(+)	(-)	7A	20	(+)	(-)	8A
8	(+)	(-)	9A	21	(+)	(-)	10A
9	(+)	(-)	11A	22	(+)	(-)	12A
10	(+)	(-)	13A	23	(+)	(-)	14A
11	(+)	(-)	15A	24	(+)	(-)	16A
12	(+)	(-)	17A	25	(+)	(-)	18A
13	(-)	(+)	COM				

Note: Gauge number of cable connecting to D-Sub pin No.13(COM) must be ≤22AWG

Explanation of 19-21 stations connection pin.

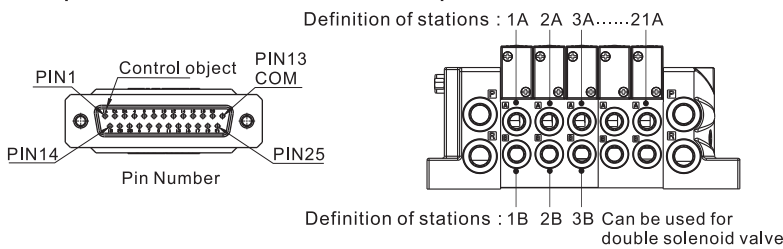

Pin NO.	Polarity		Control object	Pin NO.	Polarity		Control object
	-COM	+COM			-COM	+COM	
1	(+)	(-)	1A	14	(+)	(-)	1B
2	(+)	(-)	2A	15	(+)	(-)	2B
3	(+)	(-)	3A	16	(+)	(-)	3B
4	(+)	(-)	4A	17	(+)	(-)	5A
5	(+)	(-)	6A	18	(+)	(-)	7A
6	(+)	(-)	8A	19	(+)	(-)	9A
7	(+)	(-)	10A	20	(+)	(-)	11A
8	(+)	(-)	12A	21	(+)	(-)	13A
9	(+)	(-)	14A	22	(+)	(-)	15A
10	(+)	(-)	16A	23	(+)	(-)	17A
11	(+)	(-)	18A	24	(+)	(-)	19A
12	(+)	(-)	20A	25	(+)	(-)	21A
13	(-)	(+)	COM				

Note: Gauge number of cable connecting to D-Sub pin No.13(COM) must be ≤22AWG

Explanation of 6DW series connection pin

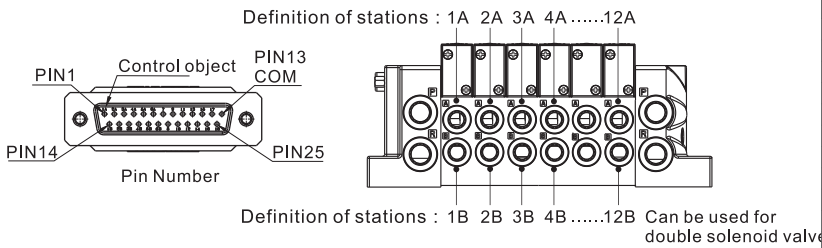

Pin NO.	Polarity		Control object	Pin NO.	Polarity		Control object
	-COM	+COM			-COM	+COM	
1	(+)	(-)	1A	14	(+)	(-)	1B
2	(+)	(-)	2A	15	(+)	(-)	2B
3	(+)	(-)	3A	16	(+)	(-)	3B
4	(+)	(-)	4A	17	(+)	(-)	4B
5	(+)	(-)	5A	18	(+)	(-)	5B
6	(+)	(-)	6A	19	(+)	(-)	6B
7	(+)	(-)	7A	20	(+)	(-)	7B
8	(+)	(-)	8A	21	(+)	(-)	8B
9	(+)	(-)	9A	22	(+)	(-)	9B
10	(+)	(-)	10A	23	(+)	(-)	10B
11	(+)	(-)	11A	24	(+)	(-)	11B
12	(+)	(-)	12A	25	(+)	(-)	12B
13	(-)	(+)	COM				

Note: Gauge number of cable connecting to D-Sub pin No.13(COM) must be ≤22AWG

Note: When mounted with single solenoid valves, B signal is empty.

5. Flip-able D-SUB portZ: horizontal and vertical side are optional.

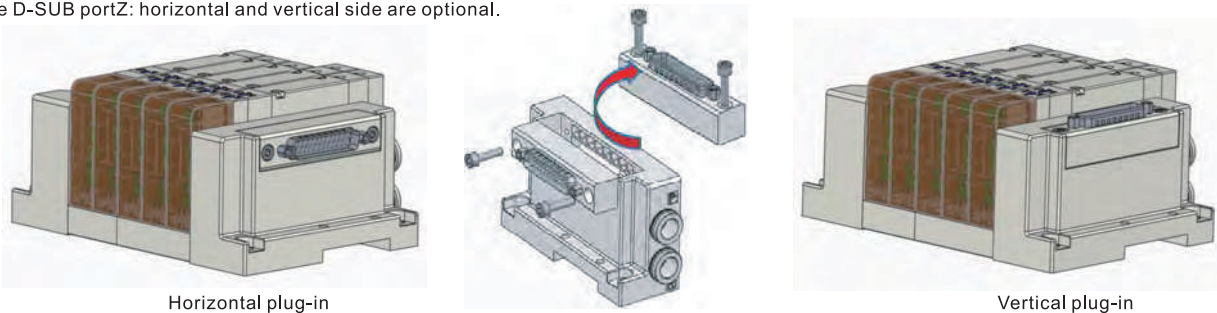

AIRTAC 6D Haberleşmeli Pnömatik Valfler/ AIRTAC 6D Communication Pneumatic Valves

Multiple communication modules and protocols are optional

Communication module No.	Protocols	Applicable model
1	PROFINET	6D0500 6D100 6D200
2	EtherNet/IP	
3	EtherCAT	
4	IO-Link	

Note: EtherCAT, IO-Link are estimated to be released in Jan 2023

Network Topology

Daisy-chain wiring

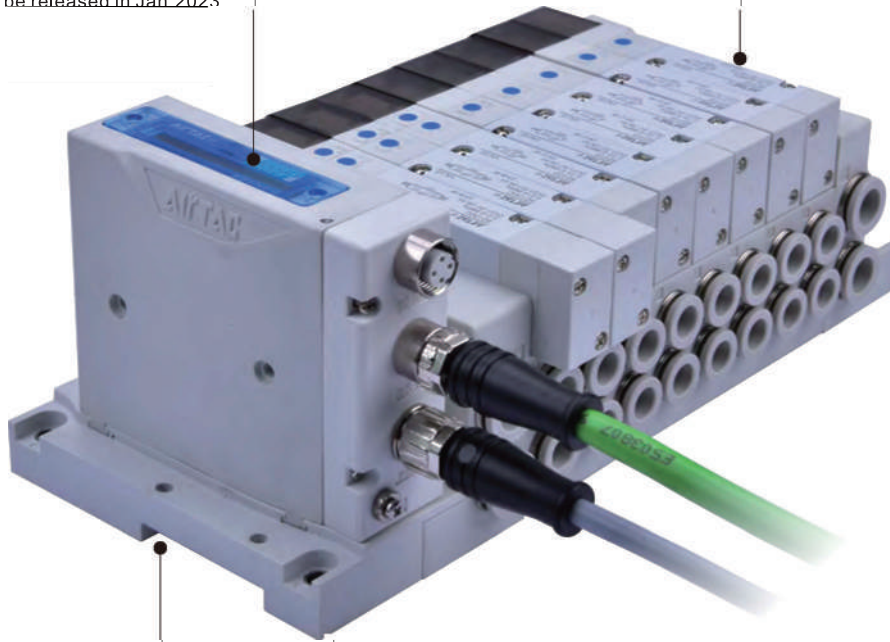
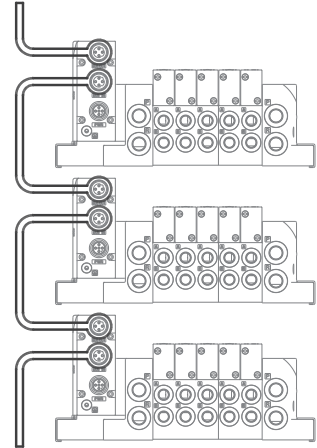

Mounting accessory

No.	Ordering code
1	F-6D0500PN-R2
2	F-6D100PN-R2
3	F-6D200PN-R2

Integration design of communication module

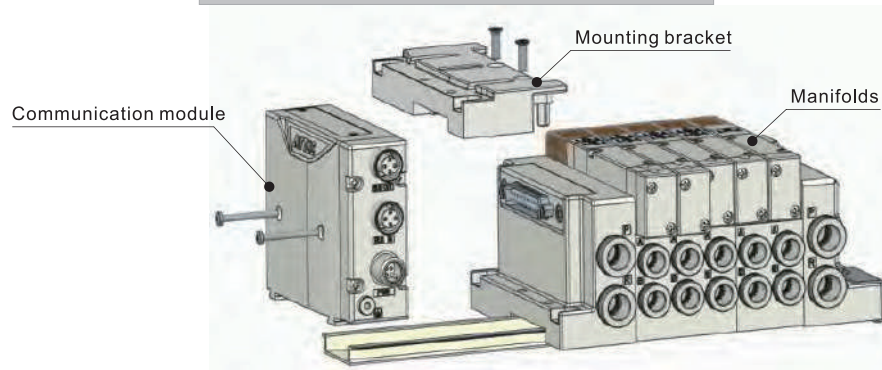



AIRTAC 6D Haberleşmeli Pnömatik Valfler/ AIRTAC 6D Communication Pneumatic Valves



Specification

Protocol	PROFINET	EtherNet/IP
Number of outputs	24 outputs	
Communication speed	100Mbps	
Configuration file	GSDML file	EDS file
Input Voltage	DC24V ± 10%	
Current consumption	<100mA	
Voltage output	DC24V ± 10%	
Output type	PNP or NPN	
Power connector	M12 plug 5 pins A-coded	
Bus connector	2XM12 socket 4 pins D-coded	
Protection	Dust proof	
Working temperature	-10~60°C	
Working humidity	35~85% RH	
Withstand voltage	AC500V 1min	Between terminals and housing
Insulation resistance	>10MΩ (DC500V), Between terminals and housing	
Communication connection	Daisy-chain wiring	

LED indicator

Profinet(C-6DPN□)

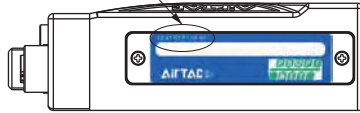
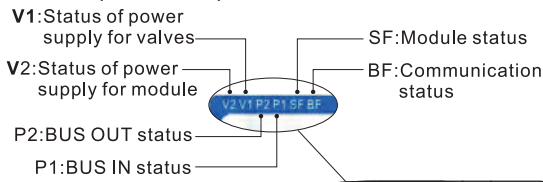

EtherNet/IP(C-6DEN□)

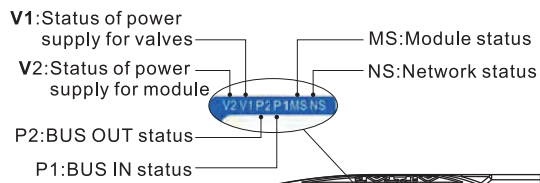

Construction and function

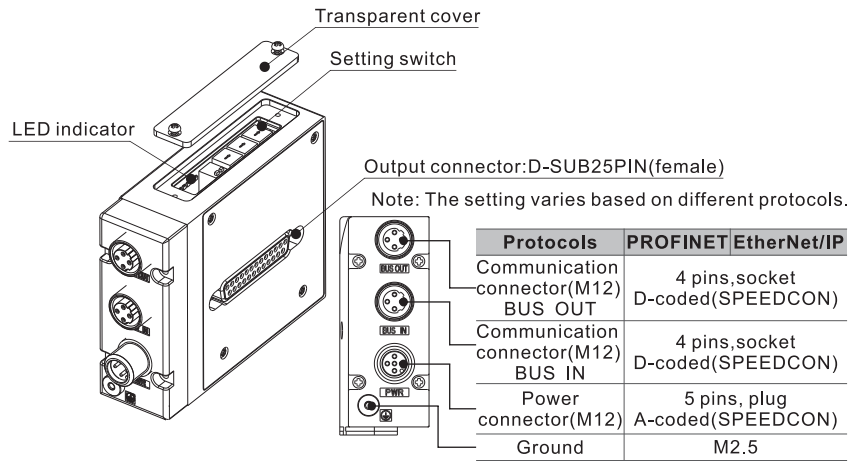

Ordering Code of communication module

C - 6D PN 1



① Model	6D : 6D series communication module	
② Protocol type	PN : Profinet	EN : EtherNet/IP
③ Output type	1 : PNP+24 outputs	2 : NPN+24 outputs

Note: 1.EtherCAT, IO-Link are estimated to be released in Jan.2023. 2.Product comes with mounting screws.

Ordering Code of communication cable

C - M12 RJ PN □ 050



M12 male connector D-coded



M12 to M12



RJ45



M12 to RJ45



① Model	C-M12 : Communication cable (M12male connector)				
② Connector type	Blank : M12 male connectors on both end		RJ : M12 male connector+RJ45 terminal		
③ Protocol type	PN : Applicable to Profinet, EtherNet/IP				
④ Cable type	Blank: Cable				
⑤ Cable length	050 : 0.5m	100 : 1m	200 : 2m	300 : 3m	500 : 5m

Note: EtherCAT, IO-Link are estimated to be released in Jan.2023.

AIRTAC 6D Haberleşmeli Pnömatik Valfler/ AIRTAC 6D Communication Pneumatic Valves

Ordering Code of power supply cable

F - M12 PN □ 150

① ② ③ ④



① Model	F-M12 : Power supply cable (M12 female connector)
② Protocol type	PN : Applicable to Profinet, EtherNet/IP
③ Cable type	Blank : Cable
④ Cable length	150 : 1.5m 300 : 3m 500 : 5m

Note: EtherCAT, IO-Link are estimated to be released in Jan.2023.

Ordering Code of mounting bracket

F - 6D0500 PN - R2

① ② ③ ④



① Model	F: Mounting accessory		
② Code	6D0500: 6D0500 Series	6D100: 6D100 Serie	6D200: 6D200 Serie
③ Protocol type	PN: For 6D module installation		
④ Output type	R2: Mounting bracket for communication module		

Note: Product comes with mounting screws.

Dimensions

6D0500 series with communication module

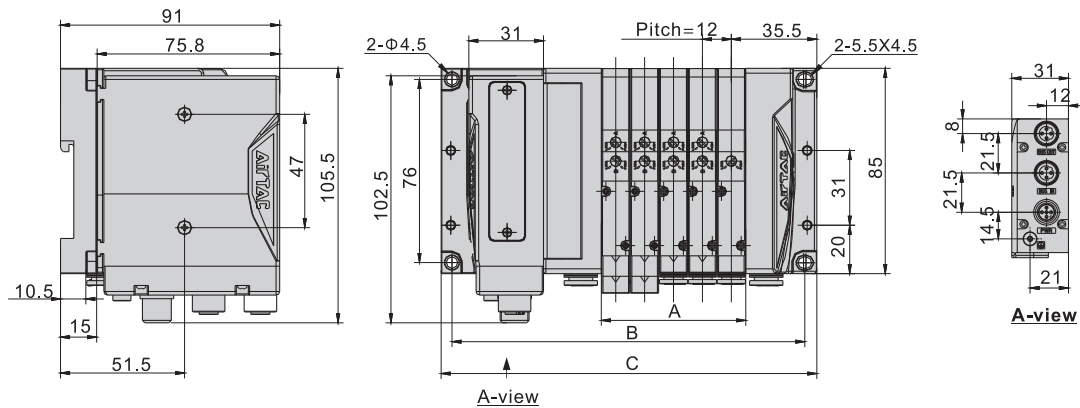

Item\Stations	3F	4F	5F	6F	7F	8F	9F	10F	11F	12F	13F	14F	15F	16F	17F	18F	19F	20F	21F
A	36	48	60	72	84	96	108	120	132	144	156	168	180	192	204	216	228	240	252
B	122.5	134.5	146.5	158.5	170.5	182.5	194.5	206.5	218.5	230.5	242.5	254.5	266.5	278.5	290.5	302.5	314.5	326.5	338.5
C	132	144	156	168	180	192	204	216	228	240	252	264	276	288	300	312	324	336	348

AIRTAC 6D Haberleşmeli Pnömatik Valfler/ AIRTAC 6D Communication Pneumatic Valves

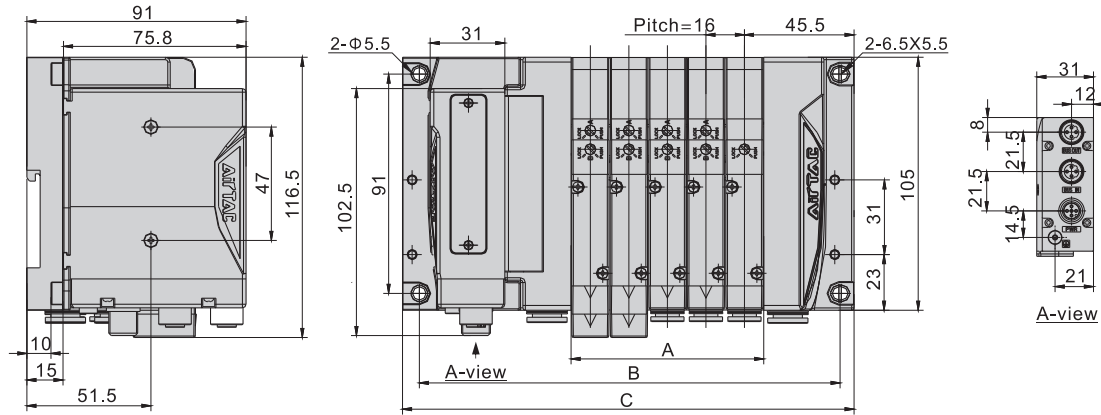
6D100 series with communication module

Item\Stations	3F	4F	5F	6F	7F	8F	9F	10F	11F	12F	13F	14F	15F	16F	17F	18F	19F	20F	21F
A	48	64	80	96	112	128	144	160	176	192	208	224	240	256	272	288	304	320	336
B	142.5	158.5	174.5	190.5	206.5	222.5	238.5	254.5	270.5	286.5	302.5	318.5	334.5	350.5	366.5	382.5	398.5	414.5	430.5
C	155.5	171.5	187.5	203.5	219.5	235.5	251.5	267.5	283.5	299.5	315.5	331.5	347.5	363.5	379.5	395.5	411.5	427.5	443.5

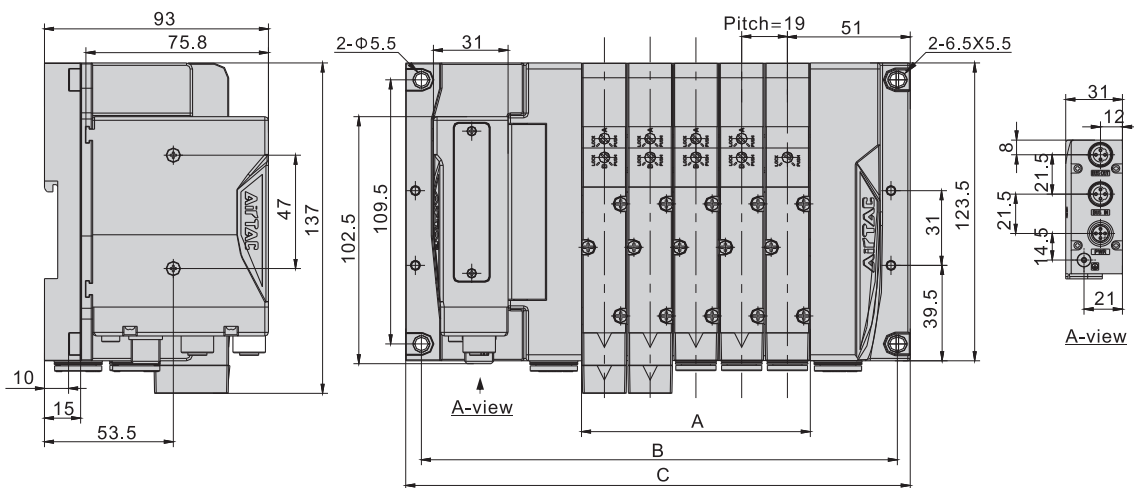
6D200 series with communication module

Item\Stations	3F	4F	5F	6F	7F	8F	9F	10F	11F	12F	13F	14F	15F	16F	17F	18F	19F	20F	21F
A	57	76	95	114	133	152	171	190	209	228	247	266	285	304	323	342	361	380	399
B	159.5	178.5	197.5	216.5	235.5	254.5	273.5	292.5	311.5	330.5	349.5	368.5	387.5	406.5	425.5	444.5	463.5	482.5	501.5
C	171.5	190.5	209.5	228.5	247.5	266.5	285.5	304.5	323.5	342.5	361.5	380.5	399.5	418.5	437.5	456.5	475.5	494.5	513.5

AIRTAC 6D Haberleşmeli Pnömatik Valfler/ AIRTAC 6D Communication Pneumatic Valves

Communication cable M12 to M12

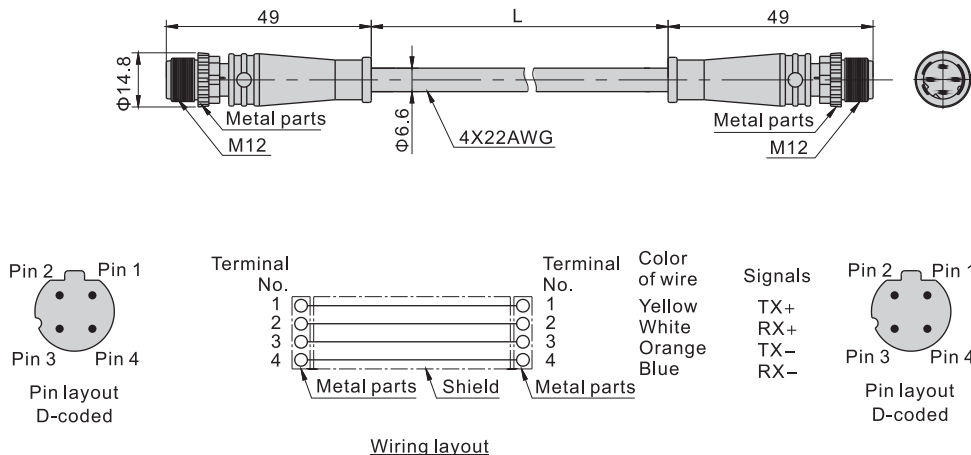

Communication cable M12 to RJ45

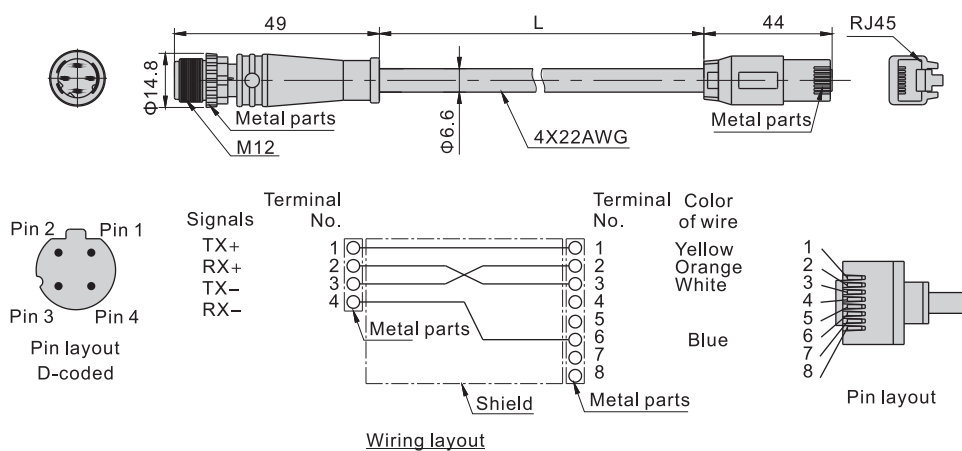

Power supply cable M12 to wires

